

Jun. 2009



SERVICE MANUAL ADDENDUM

IC-M71

CONTENTS

PARTS LIST	1
BOARD LAYOUTS	7
VOLTAGE DIAGRAM	9

[RF UNIT]

REF NO.	PARTS NO.	DESCRIPTION	M.	H/V LOCATION
C34	4030017550	S.CER ECJ0EC1H1R5B	B	20.2/28.5
C35	4030017460	S.CER ECJ0EB1E102K	B	18.5/24.6
C36	4030017460	S.CER ECJ0EB1E102K	B	14.7/30.3
C37	4030017530	S.CER ECJ0EC1H0R5B	B	16.1/29.1
C38	4030017460	S.CER ECJ0EB1E102K	B	10.8/27.1
C39	4030017630	S.CER ECJ0EC1H120J	B	10.8/29.2
C40	4030017640	S.CER ECJ0EC1H150J	B	13.1/26.9
C41	4030017460	S.CER ECJ0EB1E102K	B	10.8/31.1
C42	4030017380	S.CER ECJ0EC1H050B	B	10.8/30.1
C43	4030017400	S.CER ECJ0EC1H220J	B	10.7/35.6
C44	4030017460	S.CER ECJ0EB1E102K	T	16.2/30.8
C50	4030017460	S.CER ECJ0EB1E102K	T	6.3/11.7
C51	4030017400	S.CER ECJ0EC1H220J	T	5.1/8.2
C52	4030017460	S.CER ECJ0EB1E102K	T	4.2/7
C53	4030017460	S.CER ECJ0EB1E102K	T	2.4/2.8
C54	4030017640	S.CER ECJ0EC1H150J	T	8.6/3
C55	4030017410	S.CER ECJ0EC1H240J	T	9.8/3.1
C56	4030016790	S.CER ECJ0EB1C103K	B	29.4/26.4
C57	4030016930	S.CER ECJ0EB1A104K	B	25.4/29.5
C58	4030016930	S.CER ECJ0EB1A104K	B	25.3/23
C59	4030017730	S.CER ECJ0EB1E471K	B	28.3/22.7
C60	4030017460	S.CER ECJ0EB1E102K	B	26.7/20.7
C61	4510008490	S.ELE EEE1CS100SR	T	18.6/16
C62	4030017460	S.CER ECJ0EB1E102K	T	16.7/13.7
C63	4030017730	S.CER ECJ0EB1E471K	T	13.9/13.6
C64	4030017460	S.CER ECJ0EB1E102K	T	12.2/3.3
C65	4030017430	S.CER ECJ0EC1H101J	T	12.4/5
C66	4030017460	S.CER ECJ0EB1E102K	T	14.3/2.5
C67	4030017730	S.CER ECJ0EB1E471K	T	18.8/12.1
C68	4030017420	S.CER ECJ0EC1H470J	T	22.2/13
C70	4030007100	S.CER C1608 CH 1H 560J-T	T	21.9/1.7
C71	4030009650	S.CER C1608 CH 1H 240J-T	T	25.9/3.7
C72	4030006860	S.CER C1608 JB 1H 102K-T	T	23.3/5.1
C73	4030017460	S.CER ECJ0EB1E102K	T	29.8/11.5
C74	4030017460	S.CER ECJ0EB1E102K	T	26.7/8.5
C80	4030017460	S.CER ECJ0EB1E102K	T	28.5/4.7
C81	4030017400	S.CER ECJ0EC1H220J	T	24.9/5
C82	4030017400	S.CER ECJ0EC1H220J	T	25.1/5.9
C83	4030017400	S.CER ECJ0EC1H220J	T	28.2/3.8
C84	4030018120	S.CER ECJ0EC1H110J	T	30.2/4.2
C85	4030017640	S.CER ECJ0EC1H150J	T	29.8/5.5
C86	4030017610	S.CER ECJ0EC1H090C	T	30.5/9.3
C87	4030017530	S.CER ECJ0EC1H0R5B	B	24.1/4.5
C88	4030017460	S.CER ECJ0EB1E102K	T	23.7/17.1
C89	4030017590	S.CER ECJ0EC1H070C	T	32.3/4.2
C90	4030007000	S.CER C1608 CH 1H 090D-T	B	23.5/2.8
C91	4030017620	S.CER ECJ0EC1H100C	B	26.7/6.2
C92	4030017360	S.CER ECJ0EC1H030B	B	27.6/9
C93	4030017460	S.CER ECJ0EB1E102K	B	31.1/10.5
C94	4030017370	S.CER ECJ0EC1H3R5B	B	26/9.2
C95	4030017650	S.CER ECJ0EC1H270J	B	29.5/15
C96	4030017460	S.CER ECJ0EB1E102K	B	23/21.4
C97	4030017360	S.CER ECJ0EC1H030B	B	26/10.8
C98	4030017340	S.CER ECJ0EC1H010B	B	27.2/10.2
C99	4030017500	S.CER ECJ0EC1H560J	B	28.1/16.6
C100	4030017560	S.CER ECJ0EC1H2R5B	B	27.4/11.4
C101	4030017610	S.CER ECJ0EC1H090C	B	23.8/18
C102	4030016790	S.CER ECJ0EB1C103K	B	19.6/18
C103	4030017420	S.CER ECJ0EC1H470J	B	19.6/18.9
C104	4030016790	S.CER ECJ0EB1C103K	B	19.7/20.1
C106	4030018900	S.CER ECJ0EB0J474K	B	22.6/17.3
C107	4030017460	S.CER ECJ0EB1E102K	B	19.6/14
C108	4030017420	S.CER ECJ0EC1H470J	B	18.7/14
C109	4030017460	S.CER ECJ0EB1E102K	B	16.9/16.8
C110	4030017680	S.CER ECJ0EC1H820J	B	15.9/19.1
C111	4030017460	S.CER ECJ0EB1E102K	B	14.9/21.5
C112	4030017370	S.CER ECJ0EC1H3R5B	B	16.2/14.3
C113	4030017540	S.CER ECJ0EC1HR75B	B	14.6/16
C114	4030017660	S.CER ECJ0EC1H330J	B	14.1/20.6
C115	4030017380	S.CER ECJ0EC1H050B	B	14/17.2
C116	4030017570	S.CER ECJ0EC1H040B	B	13/16
C119	4030017500	S.CER ECJ0EC1H560J	B	7.3/17.9
C120	4030016970	S.CER ECJ0EB1C223K	B	8.2/17.5
C121	4030017460	S.CER ECJ0EB1E102K	B	7.2/16.4
C122	4030017460	S.CER ECJ0EB1E102K	T	7.6/18.6
C123	4030017460	S.CER ECJ0EB1E102K	T	7.9/13.3
C130	4030017640	S.CER ECJ0EC1H150J	T	8.2/17.1
C131	4030017620	S.CER ECJ0EC1H100C	T	7.9/12.4
C132	4030017550	S.CER ECJ0EC1H1R5B	B	6.8/14.3
C154	4030017460	S.CER ECJ0EB1E102K	B	4.7/11.7
C155	4030017580	S.CER ECJ0EC1H060C	T	3.7/20.8
C156	4030017460	S.CER ECJ0EB1E102K	B	2.6/29.6
C157	4030016970	S.CER ECJ0EB1C223K	B	4.7/29.2
C158	4030017460	S.CER ECJ0EB1E102K	B	3.8/29.2
C159	4030016790	S.CER ECJ0EB1C103K	B	7.9/25.2
C160	4030016950	S.CER ECJ0EB1A473K	B	10.1/21.6
C191	4030016790	S.CER ECJ0EB1C103K	T	19.7/27.7
C192	4550006050	S.TAN TEESVA OJ 106M8R	T	21.6/32.5
C193	4030016790	S.CER ECJ0EB1C103K	T	21.6/29.1
C194	4030016790	S.CER ECJ0EB1C103K	T	20/30
C220	4550006250	S.TAN TEESVA 1A 106M8R	T	14.3/26.9
C221	4030016790	S.CER ECJ0EB1C103K	T	18.1/23.5
C223	4030016790	S.CER ECJ0EB1C103K	T	26.1/17.3
C225	4030007020	S.CER C1608 CH 1H 120J-T	T	21.9/4.4
C226	4030017610	S.CER ECJ0EC1H090C	B	27.6/5.3
C380	4030017460	S.CER ECJ0EB1E102K	B	27.7/20.4
C381	4030017460	S.CER ECJ0EB1E102K	B	25.9/30.4
C510	4030017460	S.CER ECJ0EB1E102K	B	1.5/3
C512	4030017460	S.CER ECJ0EB1E102K	B	2.7/1.2
J101	6510025121	S.CON 30RF-JMCS-G-1B-TF(N)(LF)(SN)	T	11.9/20
S250	2260002800	S.SWI SW-167 (SKQTLAE010)	T	20.1/39.8

[RF UNIT]

REF NO.	PARTS NO.	DESCRIPTION	M.	H/V LOCATION
S328	2260002800	S.SWI SW-167 (SKQTLAE010)	T	5.1/39.8
EP2	6910014690	S.BEA MPZ1608S221A-T	T	15.5/14.9
EP3	6910014690	S.BEA MPZ1608S221A-T	T	18.4/13.3
MP20	8510016470	S.CAS 2775 VCO CASE	B	16.5/30.6
MP50	8410002620	S.HEA 2905 PA HEATSINK Y832	B	12.6/7.8

M.=Mounted side (T: Mounted on the Top side, B: Mounted on the Bottom side)
S.=Surface mount

[MIC BOARD]

REF NO.	PARTS NO.	DESCRIPTION	M.	H/V LOCATION
C700	4030017420	S.CER ECJ0EC1H470J	B	3.4/2.3
C702	4030017420	S.CER ECJ0EC1H470J	B	12.5/7.1
C703	4030017620	S.CER ECJ0EC1H100C	B	6.6/7.7
J415	6510025142	S.CON 10FLT-SM2-TB(LF)(SN)(M)	B	10.7/2.5
J416	6510021941	CON 246S-550-4P-68(JIS8)		
W470	8900014801	CAB OPC-1573-1(P0.5,N10,L50) <TJM>		
EP451	6910012350	S.BEA MMZ1608Y 102BT	B	3.4/4.8
EP452	6910012350	S.BEA MMZ1608Y 102BT	B	5.5/9
EP454	6910012350	S.BEA MMZ1608Y 102BT	B	6.3/2.8
EP458	6910012350	S.BEA MMZ1608Y 102BT	B	11.4/6.9

[VR BOARD]

REF NO.	PARTS NO.	DESCRIPTION	M.	H/V LOCATION
R801	7210003130	VAR TP76N97N-13F-10KA-2497		

M.=Mounted side (T: Mounted on the Top side, B: Mounted on the Bottom side)
S.=Surface mount

BOARD LAYOUTS

The combination of top side and bottom side of this page shows the actual configuration of P.C. board.

• MAIN UNIT (TOP VIEW)

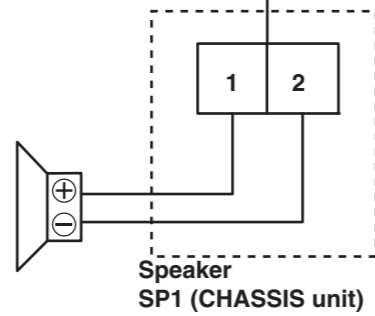
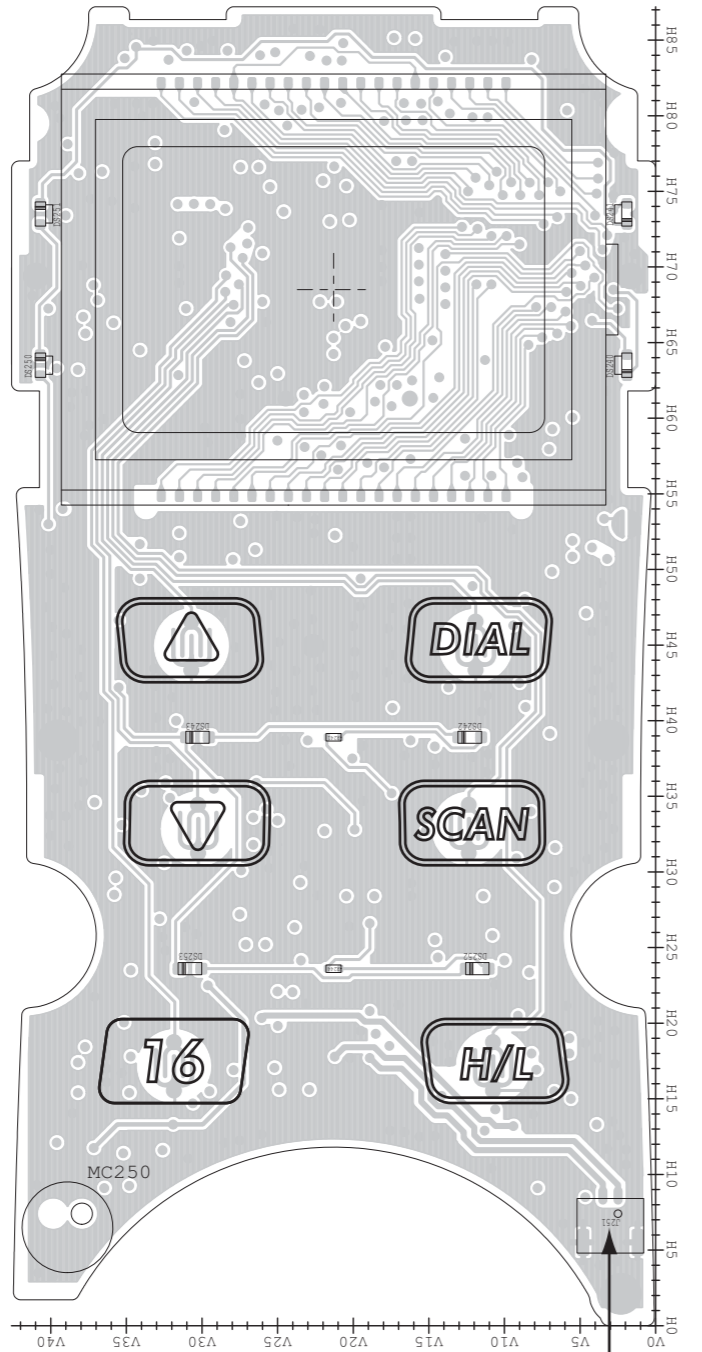

• VR BOARD (TOP VIEW)

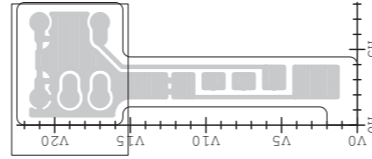

• MIC BOARD (TOP VIEW)

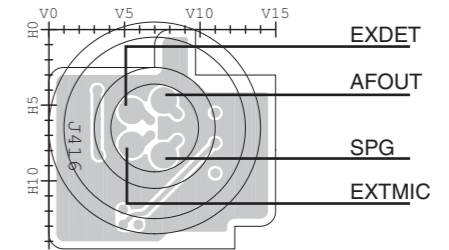

• RF UNIT (TOP VIEW)

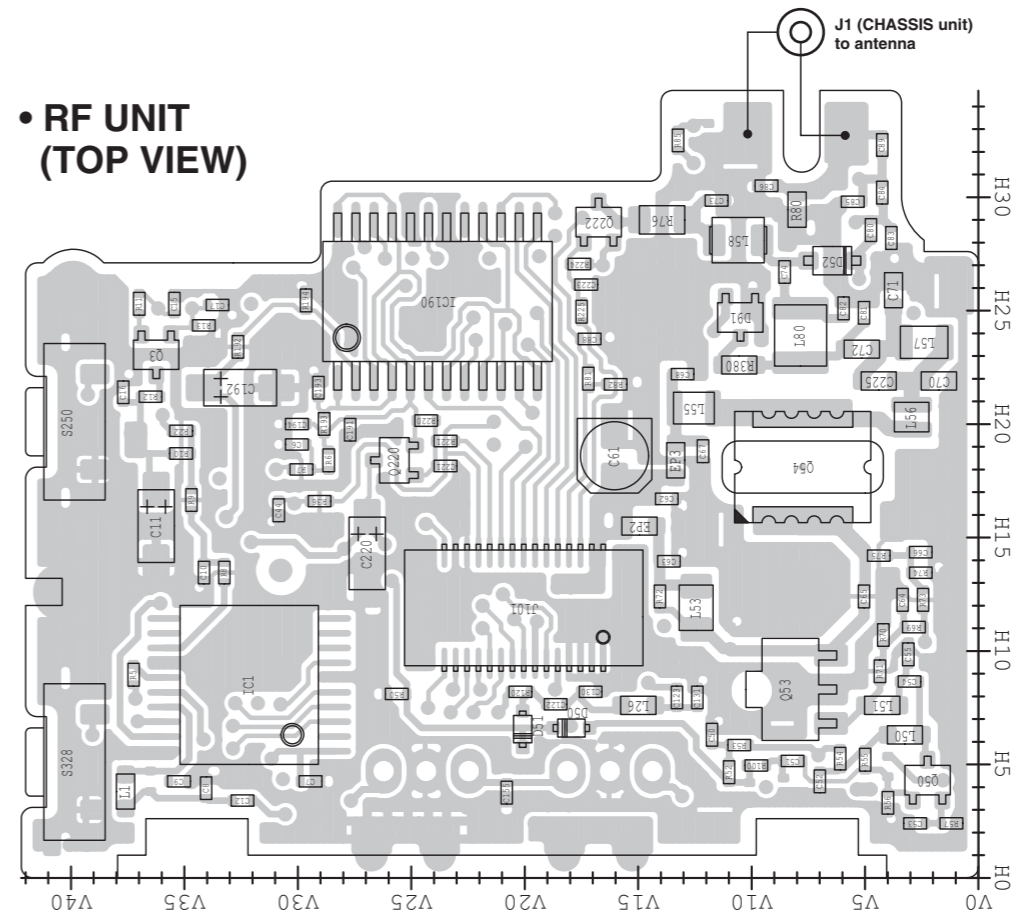

J101

30	MOD	GND	2
	TEMPV	GND	
	PLST	RSV	
	UNLK	V5VS	
	SDATA	LOINV	
	SOL	SCK	
	PTT	RSSIV	
	2NDLO	TXMS	
	PWON	SOLO	
	V5	SOLI	
	GND	TIDETV	
	GND	TSVS	
	GND	VCC	
29	GND	VCC	1

to MAIN UNIT "J100"

• MIC BOARD (BOTTOM VIEW)

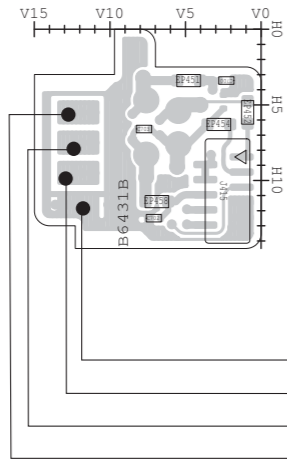

J415

2	AFOUT	EXDET	1
	AFOUT	EXTMIC	
	SPG	VOLIN	
	PWON	GND	
10	VOLOUT	GND	9

to MAIN UNIT "J300"

• VR BOARD (BOTTOM VIEW)

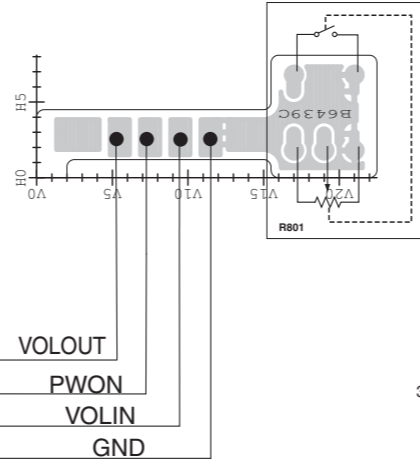

VOLOUT
PWON
VOLIN
GND

J100

30	MOD	IF	29
	GND	TEMPV	
	GND	PLST	
	R5V	UNLK	
	V5VS	SDATA	
	LOINV	SQL	
	DAST	SCK	
	RSSIV	PTT	
	TXMS	2NDLO	
	SQLQ	PWON	
	SQLI	5V	
	TDETV	GND	
	T5VS	GND	
	VCC	GND	
2	VCC	GND	1

to RF UNIT "J101"

• RF UNIT (BOTTOM VIEW)

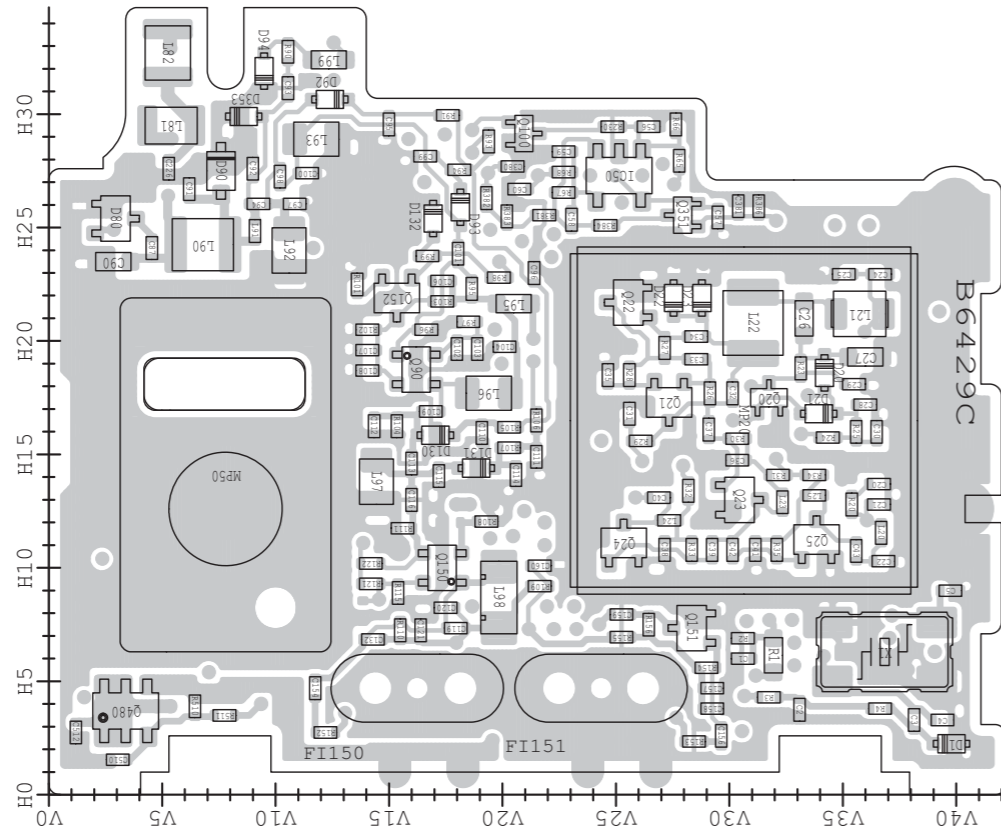

• MAIN UNIT (BOTTOM VIEW)

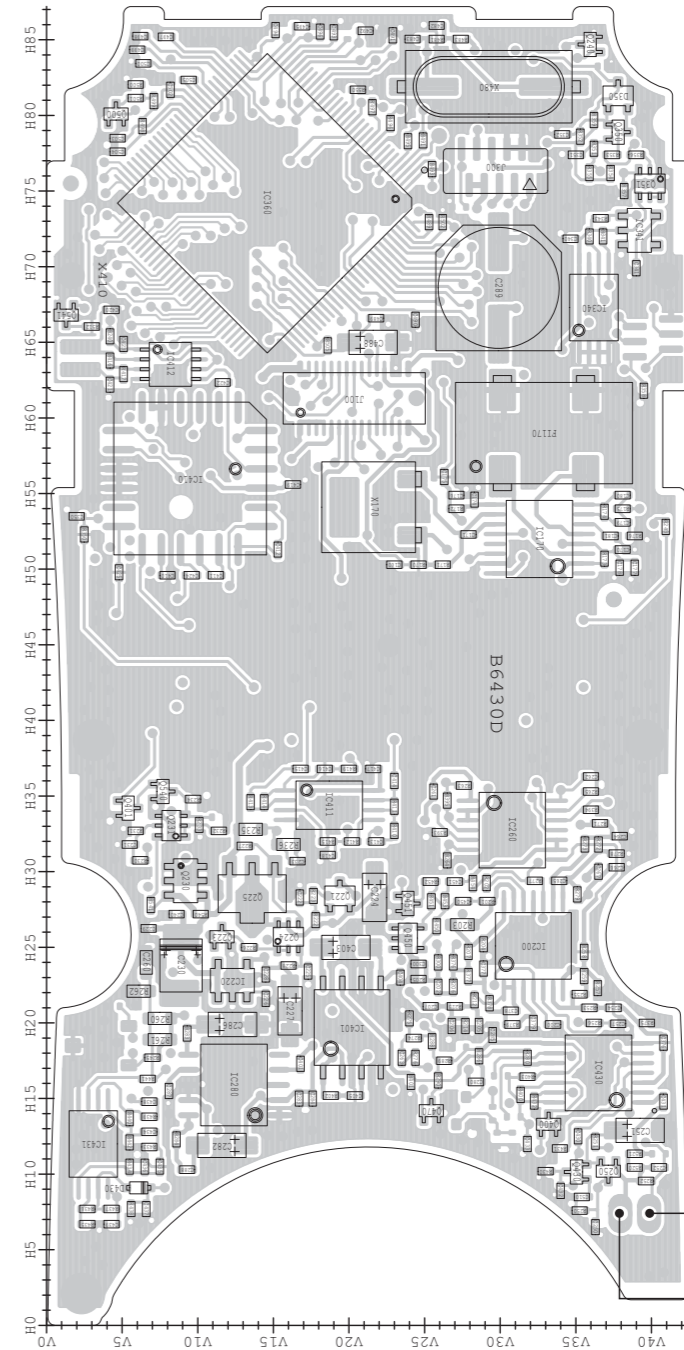

J300

2	GND	VOLOUT	1
	GND	PWON	
	VOLIN	MICE	
	EXTMIC	AFOUT	
10	EXDET	AFOUT	9

to MIC UNIT "J415"

Microphone MC250

VOLTAGE DIAGRAM

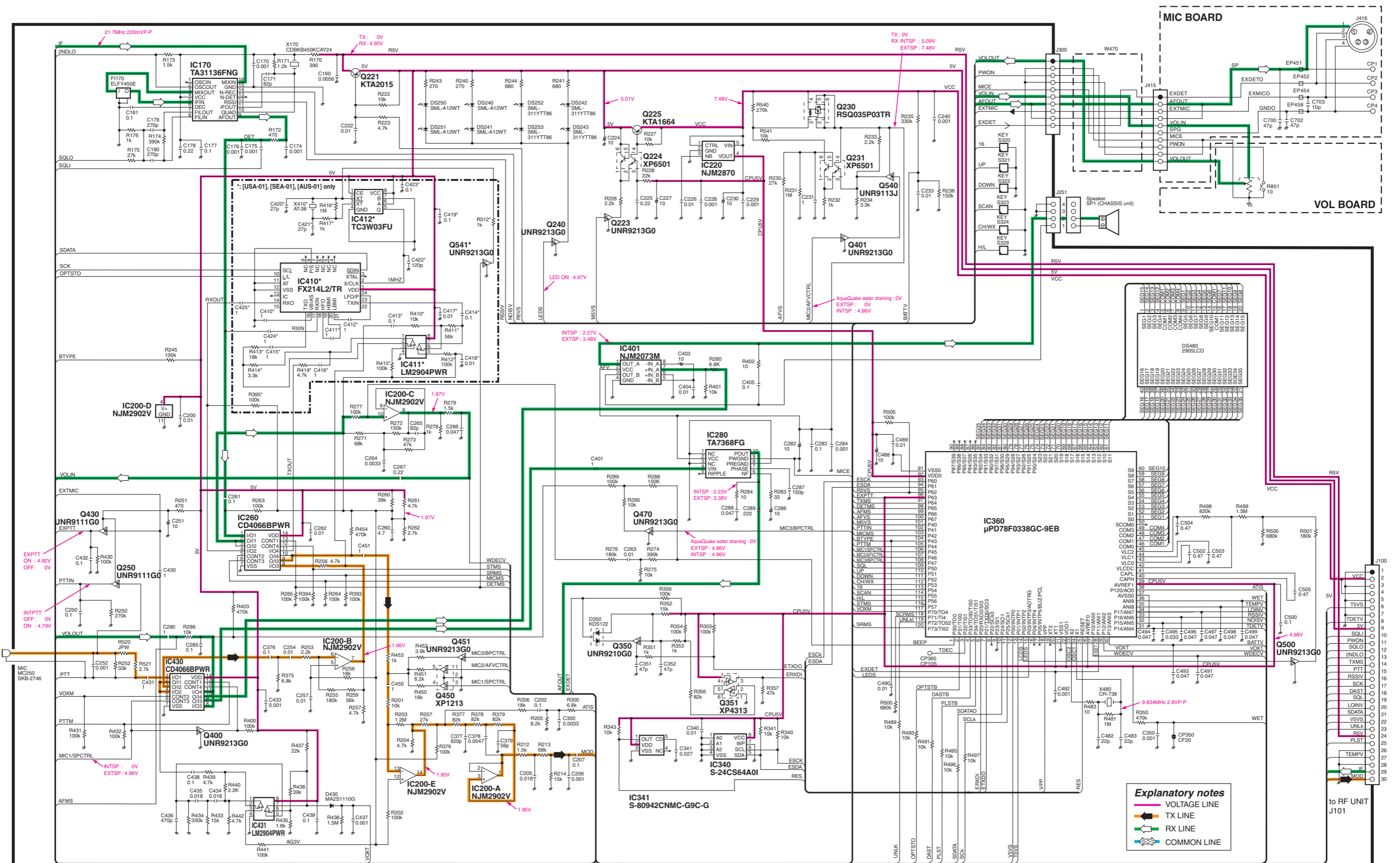

MAIN UNIT

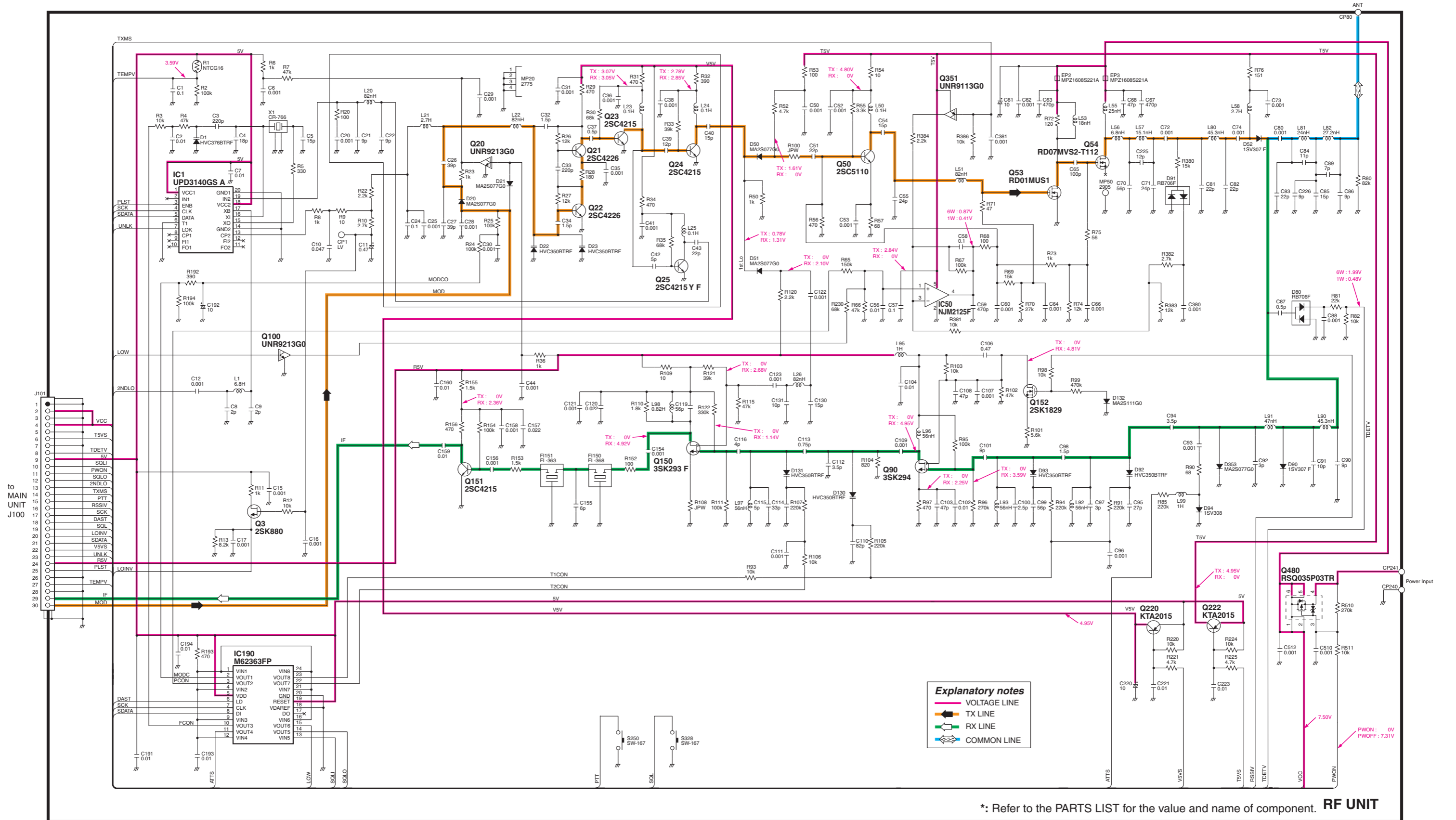

*: Refer to the PARTS LIST for the value and name of component. RF UNIT



SERVICE MANUAL

VHF MARINE TRANSCEIVER

IC-M71

S-14224MZ-C1

Feb. 2006

Icom Inc.

INTRODUCTION

This service manual describes the latest service information for the **IC-M71** VHF MARINE TRANSCEIVER at the time of publication.

VERSION	SYMBOL	SCRAMBLER	TX POWER
Europe	[EUR]	Non-Compatible	6 W
	[EUR-1]	Compatible	
U.K	[UK]	Non-Compatible	
	[UK-1]	Compatible	
Holland	[HOL]	Non-Compatible	
	[HOL-1]	Compatible	
Germany	[FRG]	Non-Compatible	1 W
	[FRG-1]	Compatible	

To upgrade quality, any electrical or mechanical parts and internal circuits are subject to change without notice or obligation.

DANGER

NEVER connect the transceiver to an AC outlet or to a DC power supply that uses more than 10 V. This will ruin the transceiver.

DO NOT reverse the polarities of the power supply when connecting the transceiver.

DO NOT apply an RF signal of more than 20 dBm (100 mW) to the antenna connector. This could damage the transceiver's front end.

ORDERING PARTS

Be sure to include the following four points when ordering replacement parts:

1. 10-digit order numbers
2. Component part number and name
3. Equipment model name and unit name
4. Quantity required

<**SAMPLE ORDER**>

1110001811 S.IC TA7368FG IC-M71 Main unit 5 pieces
8930068440 2905 Keyboard IC-M71 Chassis 10 pieces

Addresses are provided on the inside back cover for your convenience.



REPAIR NOTES

1. Make sure a problem is internal before disassembling the transceiver.
2. **DO NOT** open the transceiver until the transceiver is disconnected from its power source.
3. **DO NOT** force any of the variable components. Turn them slowly and smoothly.
4. **DO NOT** short any circuits or electronic parts. An insulated turning tool **MUST** be used for all adjustments.
5. **DO NOT** keep power ON for a long time when the transceiver is defective.
6. **DO NOT** transmit power into a signal generator or a sweep generator.
7. **ALWAYS** connect a 40 dB to 50 dB attenuator between the transceiver and a deviation meter or spectrum analyzer when using such test equipment.
8. **READ** the instructions of test equipment thoroughly before connecting equipment to the transceiver.

Icom, Icom Inc. and ICOM logo are registered trademarks of Icom Incorporated (Japan) in the United States, the United Kingdom, Germany, France, Spain, Russia and/or other countries.

TABLE OF CONTENTS

SECTION 1	SPECIFICATIONS	
SECTION 2	INSIDE VIEWS	
SECTION 3	DISASSEMBLY INSTRUCTIONS	
SECTION 4	CIRCUIT DESCRIPTION	
4 - 1	RECEIVER CIRCUITS	4 - 1
4 - 2	TRANSMITTER CIRCUITS	4 - 2
4 - 3	PLL CIRCUITS	4 - 3
4 - 4	OTHER CIRCUITS	4 - 4
4 - 5	POWER SUPPLY CIRCUITS	4 - 4
4 - 6	PORT ALLOCATIONS	4 - 4
SECTION 5	ADJUSTMENT PROCEDURES	
5 - 1	PREPARATION	5 - 1
5 - 2	SOFTWARE ADJUSTMENT	5 - 4
SECTION 6	PARTS LIST	
SECTION 7	MECHANICAL PARTS AND DISASSEMBLY	
SECTION 8	SEMICONDUCTOR INFORMATION	
SECTION 9	BOARD LAYOUTS	
SECTION 10	BLOCK DIAGRAM	
SECTION 11	VOLTAGE DIAGRAM	
SECTION 12	BC-166 INFORMATION	

SECTION 1 SPECIFICATIONS

GENERAL	• Frequency coverage	TX	156.000–161.450 MHz	
		RX	156.000–163.425 MHz	
	• Type of emission	16K0G3E		
	• Antenna impedance	50 Ω (nominal)		
	• Operating temperature range	–15°C to +55°C		
	• Power supply requirement	Specified Icom's battery pack only (operating voltage 7.2 V DC; negative ground)		
	• Current drain (approx.)	RX (Max. audio)	0.4 A (internal speaker)	
			0.2 A (external speaker)	
		TX	at 6 W	1.7 A
			at 3 W	1.3 A
at 1 W			0.7 A	
at 0.5 W	0.6 A			
• Dimensions (projections not included)	52.5(W) \times 125(H) \times 30(D) mm			
• Weight (approx.)	280 g (Including BP-245)			
TRANSMITTER	• Output power	High	6 W (Except [FRG], [FRG-1])	
			1 W ([FRG], [FRG-1])	
		Middle	3 W (Except [FRG], [FRG-1] only)	
		Low	1 W (Except [FRG], [FRG-1])	
	0.5 W ([FRG], [FRG-1])			
	• Modulation	Variable reactance frequency modulation		
	• Max. frequency deviation	\pm 5 kHz		
	• Frequency error	\pm 1.5 kHz		
	• Spurious emissions	0.25 μ W		
	• Adjacent channel power	70 dB		
	• Audio harmonic distortion	10% (at 60% deviation)		
	• Residual modulation	40 dB		
	• Audio frequency response	+1 dB to –3 dB of 6 dB oct. from 300 Hz to 3000 Hz		
• Microphone impedance	2 k Ω			
RECEIVER	• Receive system	Double-conversion super heterodyne		
	• Intermediate frequency	1st; 21.7 MHz, 2nd; 450 kHz		
	• Sensitivity	–2 dB μ emf (at 20 dB SINAD) typ.		
	• Squelch sensitivity	–6 dB μ emf typ. (at threshold) typ.		
	• Adjacent channel selectivity	70 dB		
	• Spurious response	70 dB		
	• Intermodulation rejection ratio	68 dB		
	• Residual modulation	40 dB		
	• Audio frequency response	+1 dB to –3 dB of –6 dB oct. from 300 Hz to 3000 Hz		
	• Audio output power	Internal speaker	0.6 W typ. (at 10% distortion with an 8 Ω load)	
		External speaker	0.2 W (at 10% distortion with an 8 Ω load)	
• Output impedance (audio)	8 Ω			

Specifications are measured in accordance with EN301-178-2.

All stated specifications are subject to change without notice or obligation.

• CHANNEL LISTS

Channel number			Frequency (MHz)	
USA	INT	CAN	Transmit	Receive
	01	01	156.050	160.650
01A			156.050	156.050
	02	02	156.100	160.700
	03	03	156.150	160.750
03A			156.150	156.150
	04		156.200	160.800
	04A		156.200	156.200
	05		156.250	160.850
05A		05A	156.250	156.250
06	06	06	156.300	156.300
	07		156.350	160.950
07A		07A	156.350	156.350
08	08	08	156.400	156.400
09	09	09	156.450	156.450
10	10	10	156.500	156.500
11	11	11	156.550	156.550
12	12	12	156.600	156.600
13 ²	13	13 ¹	156.650	156.650
14	14	14	156.700	156.700
15 ²	15 ¹	15 ¹	156.750	156.750
16	16	16	156.800	156.800
17 ¹	17	17 ¹	156.850	156.850
	18		156.900	161.500
18A		18A	156.900	156.900
	19		156.950	161.550

Channel number			Frequency (MHz)	
USA	INT	CAN	Transmit	Receive
19A		19A	156.950	156.950
20	20	20 ¹	157.000	161.600
20A			157.000	157.000
	21	21	157.050	161.650
21A		21A	157.050	157.050
		21b	Rx only	161.650
	22		157.100	161.700
22A		22A	157.100	157.100
	23	23	157.150	161.750
23A			157.150	157.150
24	24	24	157.200	161.800
25	25	25	157.250	161.850
		25b	Rx only	161.850
26	26	26	157.300	161.900
27	27	27	157.350	161.950
28	28	28	157.400	162.000
		28b	Rx only	162.000
	60	60	156.025	160.625
	61		156.075	160.675
61A		61A	156.075	156.075
	62		156.125	160.725
		62A	156.125	156.125
	63		156.175	160.775
63A			156.175	156.175
	64	64	156.225	160.825

Channel number			Frequency (MHz)	
USA	INT	CAN	Transmit	Receive
64A		64A	156.225	156.225
	65		156.275	160.875
65A	65A	65A	156.275	156.275
	66		156.325	160.925
66A	66A	66A ¹	156.325	156.325
67 ²	67	67	156.375	156.375
68	68	68	156.425	156.425
69	69	69	156.475	156.475
70 ³	70 ³	70 ³	156.525	156.525
71	71	71	156.575	156.575
72	72	72	156.625	156.625
73	73	73	156.675	156.675
74	74	74	156.725	156.725
77 ¹	77	77 ¹	156.875	156.875
	78		156.925	161.525
78A		78A	156.925	156.925
	79		156.975	161.575
79A		79A	156.975	156.975
	80		157.025	161.625
80A		80A	157.025	157.025
	81		157.075	161.675
81A		81A	157.075	157.075
	82		157.125	161.725
82A		82A	157.125	157.125
	83	83	157.175	161.775

Channel number			Frequency (MHz)	
USA	INT	CAN	Transmit	Receive
83A		83A	157.175	157.175
		83b	Rx only	161.775
84	84	84	157.225	161.825
84A			157.225	157.225
85	85	85	157.275	161.875
85A			157.275	157.275
86	86	86	157.325	161.925
86A			157.325	157.325
87	87	87	157.375	161.975
87A			157.375	157.375
88	88	88	157.425	162.025
88A			157.425	157.425
WX channel	Frequency (MHz)			
	Transmit	Receive		
1	RX only		162.550	
2	RX only		162.400	
3	RX only		162.475	
4	RX only		162.425	
5	RX only		162.450	
6	RX only		162.500	
7	RX only		162.525	
8	RX only		161.650	
9	RX only		161.775	
10	RX only		163.275	

¹Low power only. ²Momentary high power. ³DSC operation only

NOTE: Simplex channels, 3, 21, 23, 61, 64, 81, 82 and 83 **CANNOT** be lawfully used by the general public in U.S.A. waters.

SECTION 2 INSIDE VIEWS

• MAIN UNIT

(Top view)

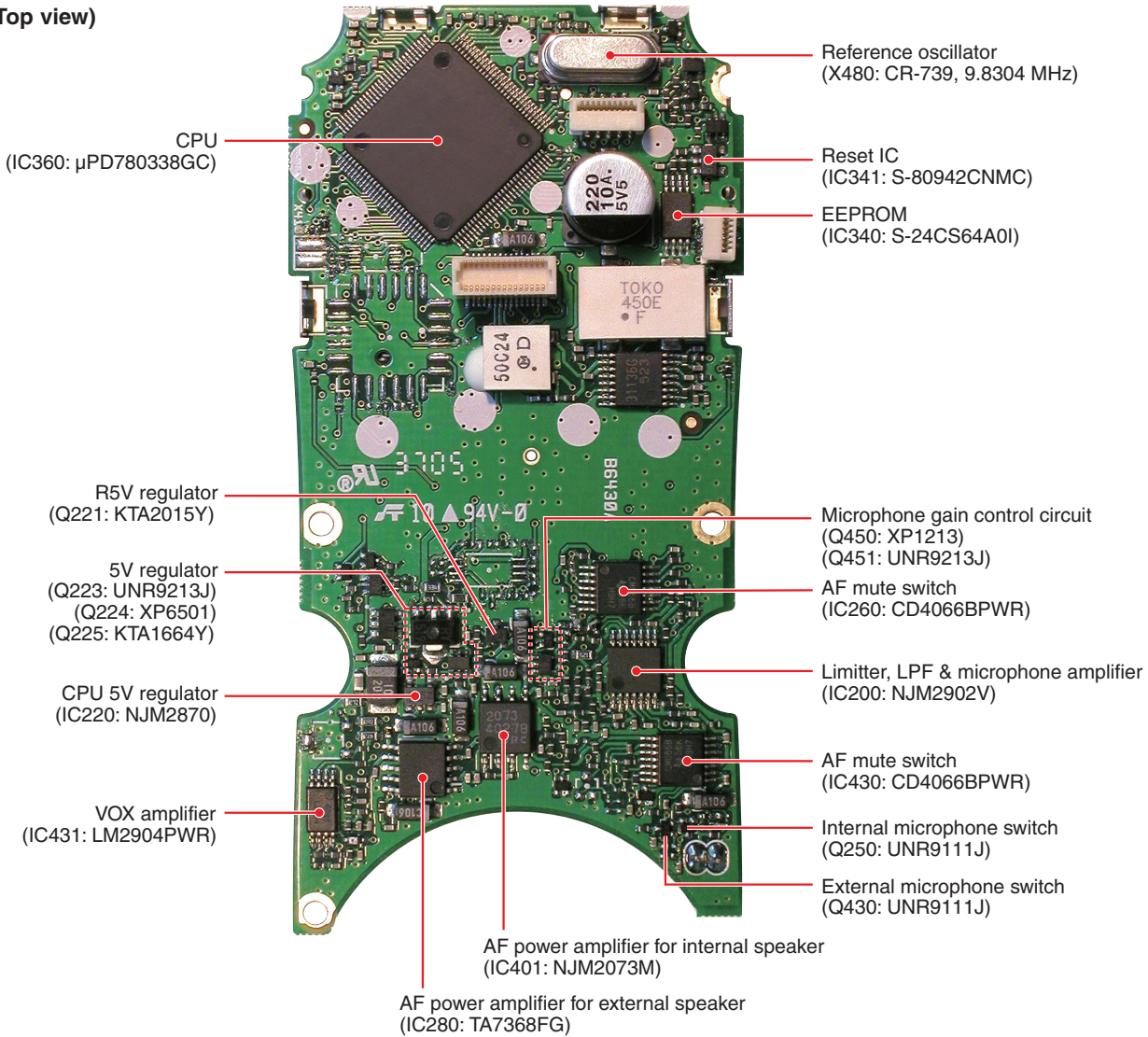

• RF UNIT

(Top view)

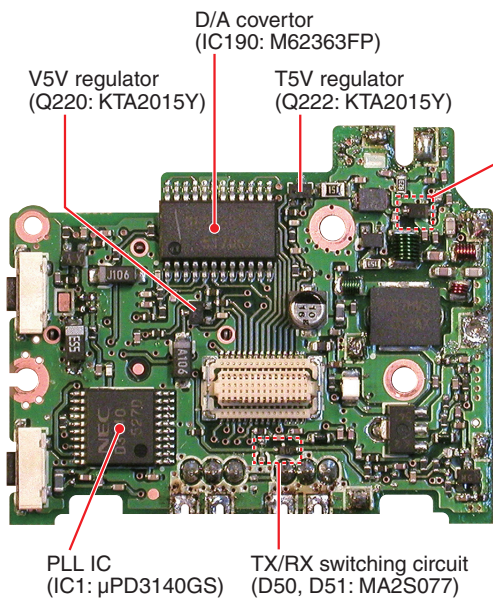

(Bottom view)

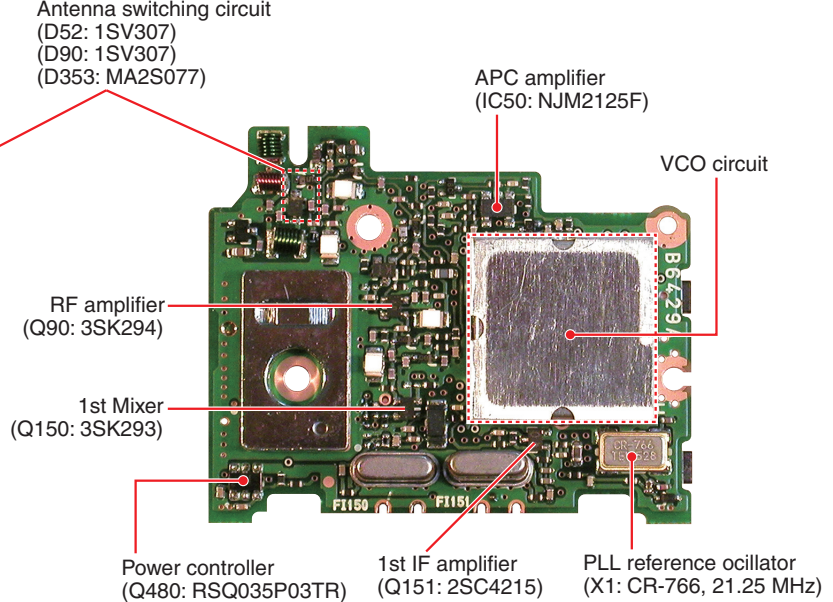

SECTION 3 DISASSEMBLY INSTRUCTIONS

1 Removing the chassis panel

- ① Unscrew 2 screws (A) and 4 screws (B).
- ② Disconnect the speaker cable (C) and remove the chassis from the front panel. (The latch is come off simultaneously)

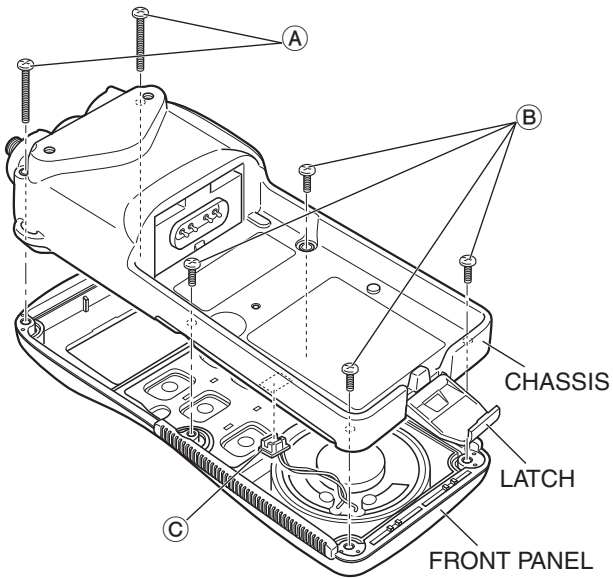

3 Removing the RF unit

- ① Unscrew 3 screws (F).
- ② Unsolder 7 points (G) and remove the RF unit.

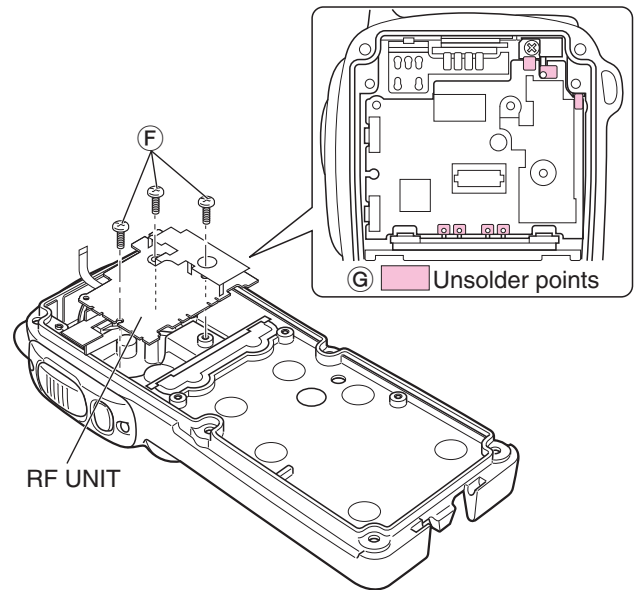

2 Removing the MAIN unit

- ① Unscrew 5 screws (D).
- ② Disconnect the flat cable (E).

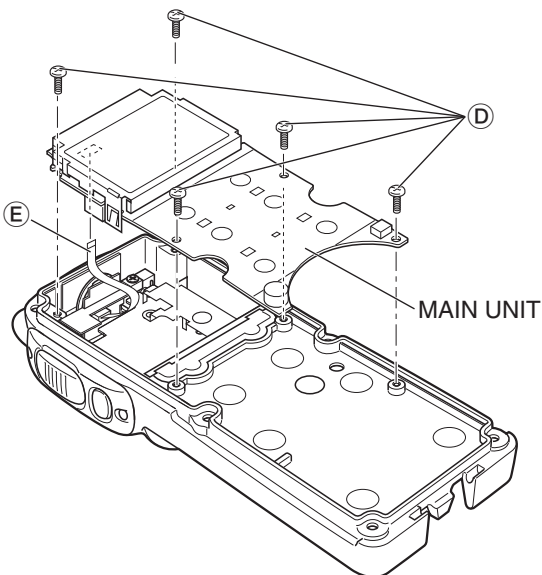

4 Removing the VR board and MIC board

- ① Remove knob (I) and connector cap (H).
- ② Unscrew connector nut (J) and VR nut (K).
- ③ Unsolder 9 points (L) and remove VR board.
- ④ Remove the VR and MIC board from the chassis.

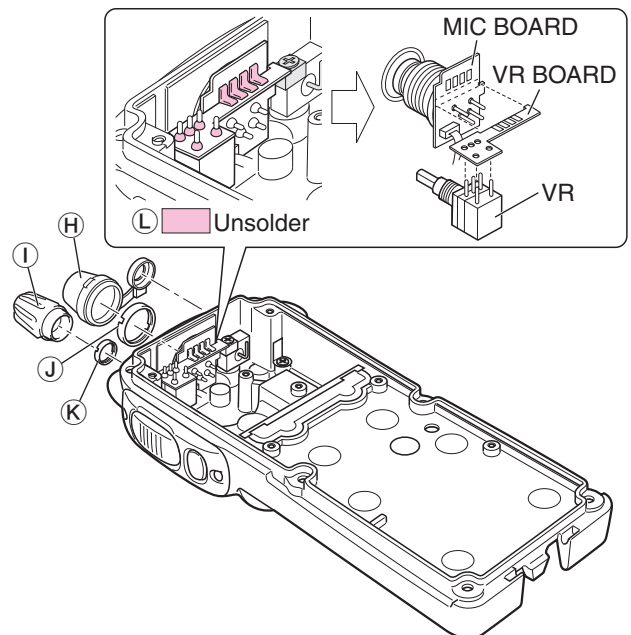

SECTION 4 CIRCUIT DESCRIPTION

4-1 RECEIVE CIRCUIT

4-1-1 ANTENNA SWITCH (RF UNIT)

The received signals from the antenna connector are passed through the antenna switch which toggles the receive (RX) line and transmit (TX) line.

The received signals from the antenna connector are passed through the low-pass filter (LPF; L81, L82, C80, C83 –C86, C89, C226) and the antenna switch (D52, D90 and D353 are OFF).

While transmitting, the voltage on the T5V line is applied to D52, D90 and D353, and these are ON. Thus the TX line is connected to the antenna, and RX line is connected to the GND to prevent transmit signal entering.

While receiving, no voltage is applied to D52, D90 and D353, and these are OFF. Thus the TX line and the antenna is disconnected to prevent received signals entering, and RX line is disconnected from the GND and L90, L91, C90 –C92 compose a two-staged LPF which guides received signals to the RX circuits.

The received signals are applied to the RF circuits.

4-1-2 RF CIRCUITS (RF UNIT)

The RF circuit amplifies received signals within the frequency coverage. The received signals are filtered at the bandpass filter (BPF) and amplified at the RF amplifier.

The received signals from the antenna switch are passed through the two-staged tunable BPF (D92, D93, L92, L93, C95, C97–C101) to filter out unwanted signals. The filtered signals are applied to the RF amplifier (Q90). The amplified signals are then applied to the 1st mixer (Q150) via another two-staged tunable BPF (D130, D131, L96, L97, C104, C109, C110, C112–C116).

4-1-3 1st IF CIRCUITS (RF UNIT)

The received signals are converted into the 1st IF signal, and amplified at the 1st IF circuits.

The amplified received signals from the RF circuits are applied to the 1st mixer (Q150), and converted into the 21.7 MHz 1st IF signal by being mixed with the 1st local oscillator (LO) signals from the VCO (Q21, Q22, D21–D23).

The converted 1st IF signal is passed through two 1st IF filters (F1150, F1151) to filter out unwanted signals, and applied to the 1st IF amplifier (Q151). The amplified 1st IF signal is then applied to the FM IF IC (MAIN UNIT; IC170, pin 16).

• 1st IF CIRCUITS

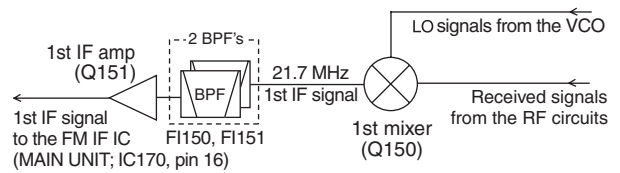

4-1-4 2nd IF AND DEMODULATOR CIRCUITS (MAIN UNIT)

The 1st IF signal is converted into the 2nd IF signal, and demodulated.

The 1st IF signal from the 1st IF circuits is applied to the 2nd IF mixer in the FM IF IC (IC170, pin 16) and converted into the 2nd IF signal by being mixed with the 21.25 MHz 2nd LO signal from the reference oscillator (RF UNIT; IC1, X1) via LPF (RF UNIT; L1, C8, C9, C12).

The converted 2nd IF signal is output from pin 3, and passed through the 2nd IF filter (F1170) to suppress sideband noise. The filtered 2nd IF signal is applied to the limiter amplifier (IC170, pin 5). The amplified 2nd IF signal is FM-demodulated at the quadrature detector (IC170, pins 10, 11) and output from pin 9. The demodulated AF signals are applied to the AF circuits.

• 2ND IF AND DEMODULATOR CIRCUITS

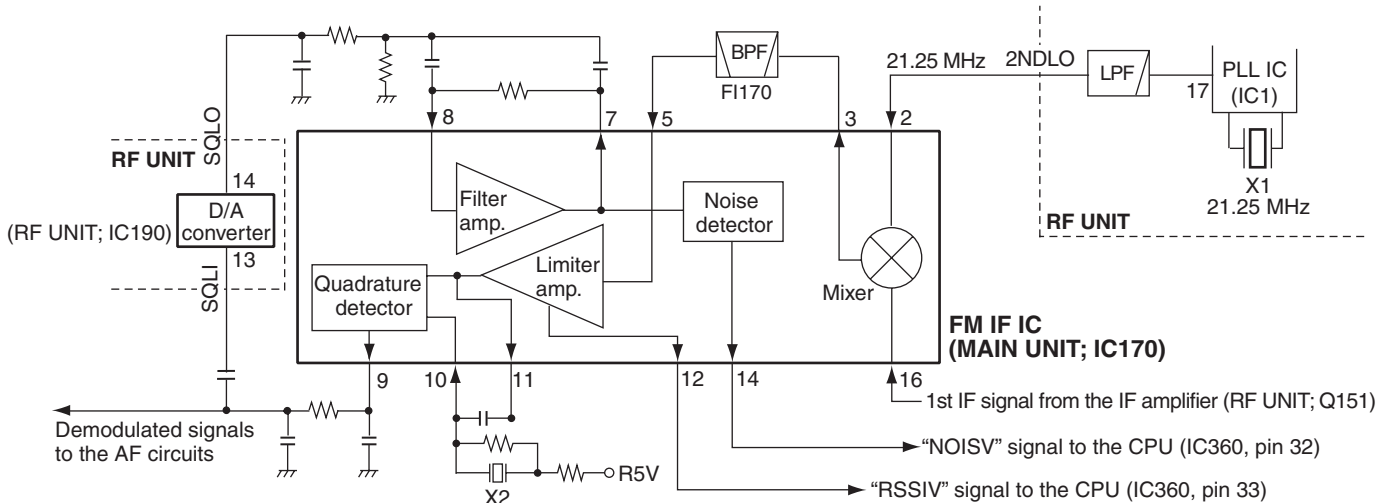

4-1-5 AF CIRCUITS (MAIN UNIT)

The demodulated AF signals from the demodulator circuits are amplified and filtered in AF amplifier circuits.

The demodulated AF signals from the FM IF IC (IC170, pin 9) are passed through the AF mute switch (IC260, pins 1, 2), LPF (IC200, pins 8, 9) and variable register (VR BOARD; R801) for level adjustment.

The level adjusted AF signals are passed through the de-emphasis circuit (R286, C280, C285) to obtain -6 dB of audio characteristic. The de-emphasized AF signals are passed through the analog switch (IC430, pins 10, 11), and applied to the AF power amplifier (IC401, pin 7) to obtain 0.6 W of AF output power. The power-amplified AF signals are then output from pin 1, and applied to the internal speaker via J251.

If an external speaker-microphone or headset is attached to the [SP MIC] connector (MIC BOARD; J416), the de-emphasized AF signals are passed through the analog switch (IC430, pins 8, 9) and applied to the AF power amplifier (IC280, pin 4) to obtain 0.2 W of AF output power. The power-amplified AF signals are output from pin 10, and then applied to the external speaker via the [SP MIC] connector (MIC BOARD; J416).

4-1-6 SQUELCH CIRCUIT (MAIN UNIT)

The squelch mutes the AF output signals when no RF signals are received. By detecting noise components in the demodulated AF signals, the squelch circuit toggles the AF power amplifier ON and OFF.

A portion of the demodulated AF signals from the FM IF IC (IC170, pin 9) are applied to the D/A converter (RF UNIT; IC190, pin 13) for level adjustment (squelch threshold adjustment). The level-adjusted AF signals are output from pin 14, and passed through the noise filter (R174-R176, C177, C179, C180). The filtered noise signals are then applied to the noise amplifier in the FM IF IC (IC170, pins 7, 8) to be amplified the noise components only.

The amplified noise components are converted into the pulse-type signal at the noise detector section, and output from pin 14 as the "NOISV" signal. The signal is applied to the CPU (IC360, pin 32), and the CPU outputs "AFVS" signal from pin 100 according to the "NOISV" signal level, to the AF power regulator (Q230, Q231, Q401, Q540) which toggles the AF power amplifier ON and OFF.

• APC CIRCUIT

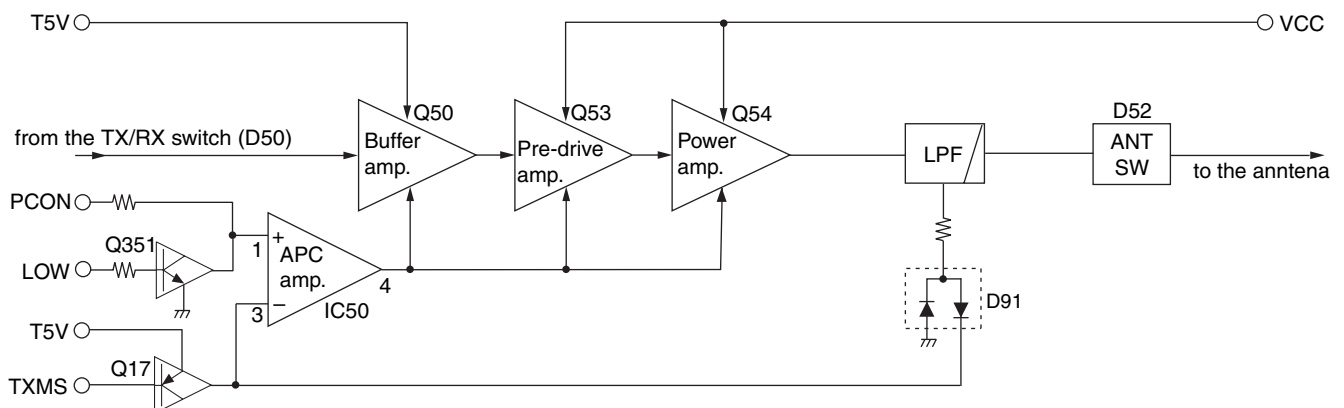

4-2 TRANSMIT CIRCUIT

4-2-1 MICROPHONE AMPLIFIER CIRCUITS (MAIN UNIT)

The AF signals from the microphone (MIC signals) are filtered and level-adjusted at microphone amplifier circuits.

The AF signals from the microphone are passed through the AF mute switch (IC430, pins 1, 2).

While an external microphone is connected to the [SP MIC] connector (MIC BOARD; J416), the mute switch shuts out the AF signals from the internal microphone (MC1).

AF signals from the AF mute switch (IC430, pins 1, 2) are passed through another AF mute switch (IC430, pins 3, 4), and passed through the pre-emphasis circuit (R253, C254) to obtain +3 dB of characteristic. The pre-emphasized signals are then applied to the microphone amplifier (IC200, pins 6, 7). The amplified MIC signals are passed through AF mute switch (IC260, pins 8, 9), and are applied to the gain controller (Q450, Q451) which adjust the AF signal level (=deviation) according to the control signals ("MIC1/2/3") from the CPU (IC360, pins 106/107/108).

The level adjusted MIC (MOD) signals are applied to the limiter amplifier (IC200, pins 13, 14) which limits the amplitude of the MIC signals to prevent over deviation. The amplitude-limited MIC signals are then passed through the splatter filter (IC200, pins 1, 3) which suppresses the 3 kHz and higher audio components.

The filtered MIC signals are applied to the modulation circuit (RF UNIT; D20).

4-2-2 MODULATION CIRCUIT (RF UNIT)

The modulation circuit modulates the VCO oscillating signal with the AF signals from the microphone.

The MIC signals from the microphone amplifier circuits are applied to the D20, and modulate the VCO oscillating signal by changing the reactance of D20. The modulated VCO output signal is buffer-amplified by Q23 and Q24, then applied to transmit amplifiers as a transmit signal via the TX/RX switch (D50 is ON, D51 is OFF).

4-2-3 TRANSMIT AMPLIFIERS (RF UNIT)

The VCO output signal is amplified to transmit output power level by the transmit amplifiers.

The transmit signal from the TX/RX switch (D50) is applied to the buffer amplifier (Q50). The amplified transmit signal is amplified to the transmit output level by the pre-driver (Q53) and power amplifier (Q54). The power-amplified transmit signal is passed through the TX power detector of APC circuit (D91), antenna switch (D52, D90 and D353 are ON), TX power detector for transmit indicator (D80) and LPF (as a harmonic filter; L81, L82, C80, C83–C86, C89, C226) before being applied to the antenna connector (CHASSIS; J1).

4-2-1 APC CIRCUIT (RF UNIT)

The APC (Automatic Power Control) circuit stabilizes transmit output power to prevent transmit output power level change which is caused by load mismatching or heat effect, etc.. The APC circuit also selects transmit output power from high, middle and low power.

The power detector circuits (D91) detects the transmit output and converts it into DC voltage which is in proportion to the transmit output power level. The detected voltage is applied to the differential amplifier (IC50, pin 3). The transmit power setting voltage "PCON" is applied to another input terminal (pin 1) as the reference voltage.

The differential amplifier compares the detected voltage and reference voltage, and the difference of the voltage is output from pin 4. The output voltage controls the bias of the buffer amplifier (Q50), pre-driver (Q53) and power amplifier (Q54) to reduce/increase the gain of transmit amplifiers for stable transmit output power.

The change of transmit power is carried out by the change of reference voltage "PCON" and "LOW."

4-3 PLL CIRCUIT

4-3-1 VCO CIRCUIT (RF UNIT)

The VCO (Q21, Q22, D21–D23) generates the both of transmit signal and LO signals for the 1st IF conversion. The VCO output signals are buffer-amplified by Q23 and Q24.

While transmitting, the VCO output signal is applied to the transmit amplifiers via TX/RX switch (D50 is ON, D51 is OFF).

While receiving, the VCO output signals are applied to the 1st mixer (Q150) via the TX/RX switch (D50 is OFF, D51 is ON) the BPF (L26, C122, C123, C130, C131), to be mixed with the received signals to produce the 21.7 MHz 1st IF signal.

A portion of the VCO output is applied to the PLL IC (IC1, pin 19) via the buffer amplifier (Q25) and LPF (L20, R20, C20–C22).

4-3-2 PLL CIRCUIT (RF UNIT)

The PLL circuit provides stable oscillation of the transmit frequency and receive 1st LO frequency. The PLL output frequency is controlled by the divided ratio (N-data) from the CPU.

The buffer-amplified signals from the LPF (L20, R20, C20–C22) are applied to the PLL IC (IC1, pin 19). The applied signals are divided at the prescaler and programmable counter according to the "SDATA (SDATAO)" signal from the CPU (MAIN UNIT; IC360, pin 10). The divided signal is phase-compared with the reference frequency signal which is divided by reference counter, at the phase detector.

The phase difference is output from pin 13 as a pulse type signal after being passed through the charge pump. The output signal is converted into the DC voltage (lock voltage) by passed through the loop filter (R8–R10, R22, C10, C11, C24, C25). The lock voltage is applied to the variable capacitors (D22, D23) of the VCO (Q21, Q22, D21–D23) and locked to keep the VCO frequency constant.

If the oscillated signal drifts, its phase changes from that of the reference frequency, causing a lock voltage change to compensate for the drift in the VCO oscillating frequency.

• PLL CIRCUITS

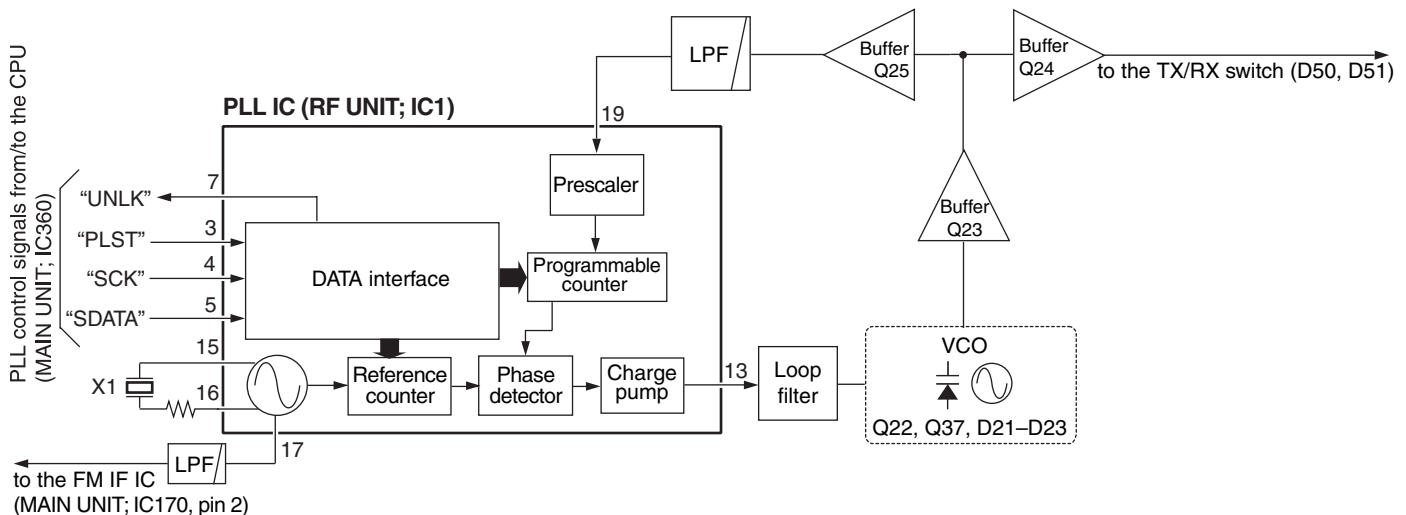

4-4 OTHER CIRCUIT

4-4-1 VOX CIRCUIT (MAIN UNIT)

The VOX circuit toggles TX and RX automatically by detecting voice signals from the microphone.

The MIC signals from the external microphone are applied to the VOX amplifier (IC431, pins 1, 2). The amplified MIC signals are applied to another VOX amplifier (IC431, pin 5), and the amplified MIC signals are output from pin 7, then rectified by D430. The rectified signal is applied to the CPU (IC360, pin 29) as "VOXT" signal which turns the transmit circuits ON. Then the CPU outputs "VOXM" signal from pin 117 to the AF mute switch (IC430, pin 5) to turn the AF mute switch OFF, and the MIC signals are applied to the pre-emphasis circuit.

4-5 POWER SUPPLY CIRCUITS (MAIN UNIT AND RF UNIT)

Line name	Description
VCC	The same voltage as attached battery pack.
CPU5V	Common 5 V converted from VCC line at the CPU5V regulator (IC220). The converted voltage is applied to the CPU (IC360), Reset IC (IC341), EEPROM (IC340), etc.
5V	Common 5 V converted from VCC line at the 5V regulator (Q223–Q225) controlled by "M5VS" signal from CPU (IC360, pin 101). The converted voltage is applied to the backlight LED'S (DS240–DS243, DS250–DS253), D/A converter (RF UNIT; IC190), PLL IC (RF UNIT; IC1), etc.
V5V	Common 5 V converted from VCC line at the V5V regulator (RF UNIT; Q220). The converted voltage is applied to the VCO (RF UNIT; Q21, Q22, D21–D23)
R5V	Receive 5 V controlled by R5V regulator (Q221) using "R5VS" signal from the CPU (IC360, pin 95). The voltage is applied to the receive circuits (RF UNIT; 1st mixer (Q150), 1st IF amplifier (Q151), RF amplifier (Q90), etc.).
T5V	Transmit 5 V controlled by T5V regulator (RF UNIT; Q222) using "T5VS" signal from the CPU (IC360, pin 13). The controlled voltage is applied to the transmit circuits (RF UNIT; differential amplifier (IC50), pre-driver (Q53), power amplifier (Q54), microphone amplifier (IC8), etc.).

4-6 PORT ALLOCATIONS

4-6-1 CPU (MAIN UNIT; IC360)

Pin No.	Port Name	Description
1	BEEP	Outputs beep sound to the AF circuits.
4	DASTB (DAST)	Outputs strobe signal to the D/A converter (RF UNIT; IC190, pin 6).
5	PLSTB (PLST)	Outputs PLL strobe signal to the PLL IC (RF UNIT; IC1, pin 3).
11	SCLK (SCK)	Outputs serial clock signal to the PLL IC (RF UNIT; IC1, pin 4), D/A converter (RF UNIT; IC190, pin 7).
12	V5VS	Outputs V5V regulator (Q220) control signal. "High"= While power save mode (The VCO (Q21, Q22, D21–D23) is not activated).
13	T5VS	Outputs T5V regulator (RF UNIT; Q222) control signal. "Low"= While transmitting. "High"= While receiving or power save mode.
14	LCDS	Outputs LCD contrast select signal. "Low"= While "Bright" is selected. "High"= While "Dark" is selected.
15	LEDS	Outputs backlight LED (DS240–DS243, DS250–DS253) control signal to the LED driver (Q240). "High"= While the backlight is ON.
25	RES	Input port for reset signal from the reset IC (IC341, pin 1).
28	EXDET	Input port for external connect detect signal.
29	VOXT	Input port for audio detect signal from the VOX amplifier (IC431, pin 7) for the VOX operation.
30	BATTV	Input port for remaining battery power.
31	TDETV	Input port for power level detect signal from the transmit power detector (RF UNIT; D80).
32	NOISV	Input port for the noise level from the FM IF IC (IC170, pin 14).
33	RSSIV	Input port for RSSI signal from the FM IF IC (IC170, pin 12).
34	LOINV	Input port for VCO (Q21, Q22, D21–D23) lock voltage.
35	TEMPV	Input port for temperature detection.
36	WET	Input port for leaking detection signal.
93	ESCK	Outputs serial clock signal to the EEPROM (IC340, pin 6).
94	ESDA	Outputs serial data to the EEPROM (IC340, pin 5).
95	R5VS	Output R5V line control signal to the R5V regulator (Q221). "High"= While receiving.
96	EXPTT	Input port for external PTT switch. "High"= While the external PTT switch is pushed.
97	TXMS	Outputs transmit mute signal to the transmit mute switch (Q351). "High"= While transmitting.
98	DETMS	Outputs mute signal to the AF mute switch (IC260, pin 13). "High"= While the squelch is open.
100	AFVS	Outputs AF power amplifier power supply switch control signal. "High"= While the audio is emitted from the internal speaker (CHASSIS; SP1) or external speaker.
102	PTTIN	Input port for [PTT] switch. (RF UNIT; S250) "High": While [PTT] switch is pushed.

4-6-1 CPU (MAIN UNIT; IC360)-continued

Pin No.	Port Name	Description
104	BTYPE	Input port for battery type detect signal.
105	PTTM	Outputs MIC mute signal to the AF mute switch (IC430, pin 13). "High": While transmitting. "Low": While transmitting in VOX operation.
106	MIC1/ SPCTRL	<ul style="list-style-type: none"> • While transmitting. Outputs microphone sensitivity control signal to the MIC gain controller (Q450, Q451). (The microphone sensitivity is determined by the combination of "MIC1–MIC3".) • While receiving. Outputs AF line switching signal to the analog switch (IC430, pins 6, 12).
107	MIC2/ AFVCTRL	<ul style="list-style-type: none"> • While transmitting. Outputs microphone sensitivity control signal to the MIC gain controller (Q450, Q451). • While receiving. Outputs AF power amplifier (IC280 or IC401) bias change signal to the AF amplifier power supply circuit (Q230, Q231, Q401, Q540).
108	MIC3/ BPCTRL	<ul style="list-style-type: none"> • While transmitting. Outputs microphone sensitivity control signal to the MIC gain controller (Q450, Q451). • While receiving. Outputs AquaQuake function activate signal. "Low": AquaQuake function is activated.
109	SQL	Input port for [SQL] key (RF UNIT; S250). "Low": While [SQL] is pushed.
110	UP	Input port for [▲] key (MAIN UNIT; S321). "Low": When [▲] key is pushed.
111	DOWN	Input port for [▼] key (MAIN UNIT; S322). "Low": When [▼] key is pushed.
112	CH/WX	Input port for [CH/WX] key (MAIN UNIT; S324). "Low": When [CH/WX] key is pushed.
113	16	Input port for [16] key (MAIN UNIT; S320). "Low": When [16] key is pushed.
114	SCAN	Input port for [SCAN] key (MAIN UNIT; S324). "Low": When [SCAN] key is pushed.
115	H/L	Input port for [H/L] key (MAIN UNIT; S329). "Low": When [H/L] is pushed.
117	VOXM	Outputs MIC mute signal to the AF mute switch (IC430, pin 5). "High": While transmitting.
119	UNLK	Input port for PLL unlock signal ("UNLK") from the PLL IC (IC1, pin 7). "High": While the PLL is unlocked.

4-6-2 D/A CONVERTER (RF UNIT; IC190)

Pin No.	Port Name	Description
2	MODC	Outputs deviation adjust signal.
3	FCON	Outputs reference frequency adjust signal.
10	PCON	Outputs transmit power setting voltage.
11	ATTS	Outputs attenuator (RF UNIT; D94) switching signal. "High"=The attenuator (RF UNIT; D94) is activated.
15	LOW	Outputs transmit power setting signal. "High"=TX power [High] or [Mid] is selected. "Low"=TX power [LOW] is selected.
22	T2CON	Outputs center frequency tracking voltage to the BPF (RF UNIT; D131, L97, C112–C116).
23	T1CON	Outputs center frequency tracking voltage to the BPF'S (RF UNIT; D130, L96, C104, C109, C110).

SECTION 5 ADJUSTMENT PROCEDURES

5-1 PREPARATION

■ REQUIRED TEST EQUIPMENTS

When adjusting IC-M71, the optional CS-M72/M71 ADJ ADJUSTMENT SOFTWARE (Rev. 1.0 or later), OPC-478 (RS-232 type) or OPC-478U (USB type) CLONING CABLE, OPC-1028 and JIG cable (see page 5-2) are required.

EQUIPMENT	GRADE AND RANGE	EQUIPMENT	GRADE AND RANGE
RF power meter (terminated type)	Measuring range : 0.1–10 W Frequency range : 100–300 MHz Impedance : 50 Ω SWR : Less than 1.2 : 1	Standard signal generator (SSG)	Frequency range : 0.1–300 MHz Output level : 0.1 μV to 32 mV (–127 to –17 dBm)
Frequency counter	Frequency range : 0.1–300 MHz Frequency accuracy: ±1 ppm or better Sensitivity : 100 mV or better	Oscilloscope	Frequency range : DC–20 MHz Measuring range : 0.01–20 V
FM deviation meter	Frequency range : 30–300 MHz Measuring range : 0 to ±10 kHz	AC millivoltmeter	Measuring range : 1 mV to 10 V
Audio generator	Frequency range : 300–3000 Hz Output level : 1–500 mV Impedance : 600 Ω	External speaker	Input impedance : 8 Ω Capacity : More than 1 W
		Attenuator	Power attenuation : 30 dB or more Capacity : More than 10 W

■ STARTING SOFTWARE ADJUSTMENT

- (1) Connect IC-M71 and a PC with OPC-478/U, OPC-1028 and JIG CABLE.
- (2) Turn the transceiver ON.
- (3) Boot up Windows®, and click the program group 'CS-M72/M71 ADJ' in the 'Programs' folder of the [Start] menu, then CS-M72/M71 ADJ's window appears.
- (4) Click 'Adjust' on the CS-M72/M71's window, then IC-M71's up-to-date condition appears.
- (5) Set or modify adjustment value as specified.

CAUTION!: BACK UP the originally programmed memory data in the transceiver before programming the adjustment frequencies.
When program the adjustment frequencies into the transceiver, the transceiver's memory data will be overwritten and lose original memory data at the same time.

Microsoft and Windows are registered trademarks of Microsoft Corporation in the U.S.A. and other countries.

• CONNECTION

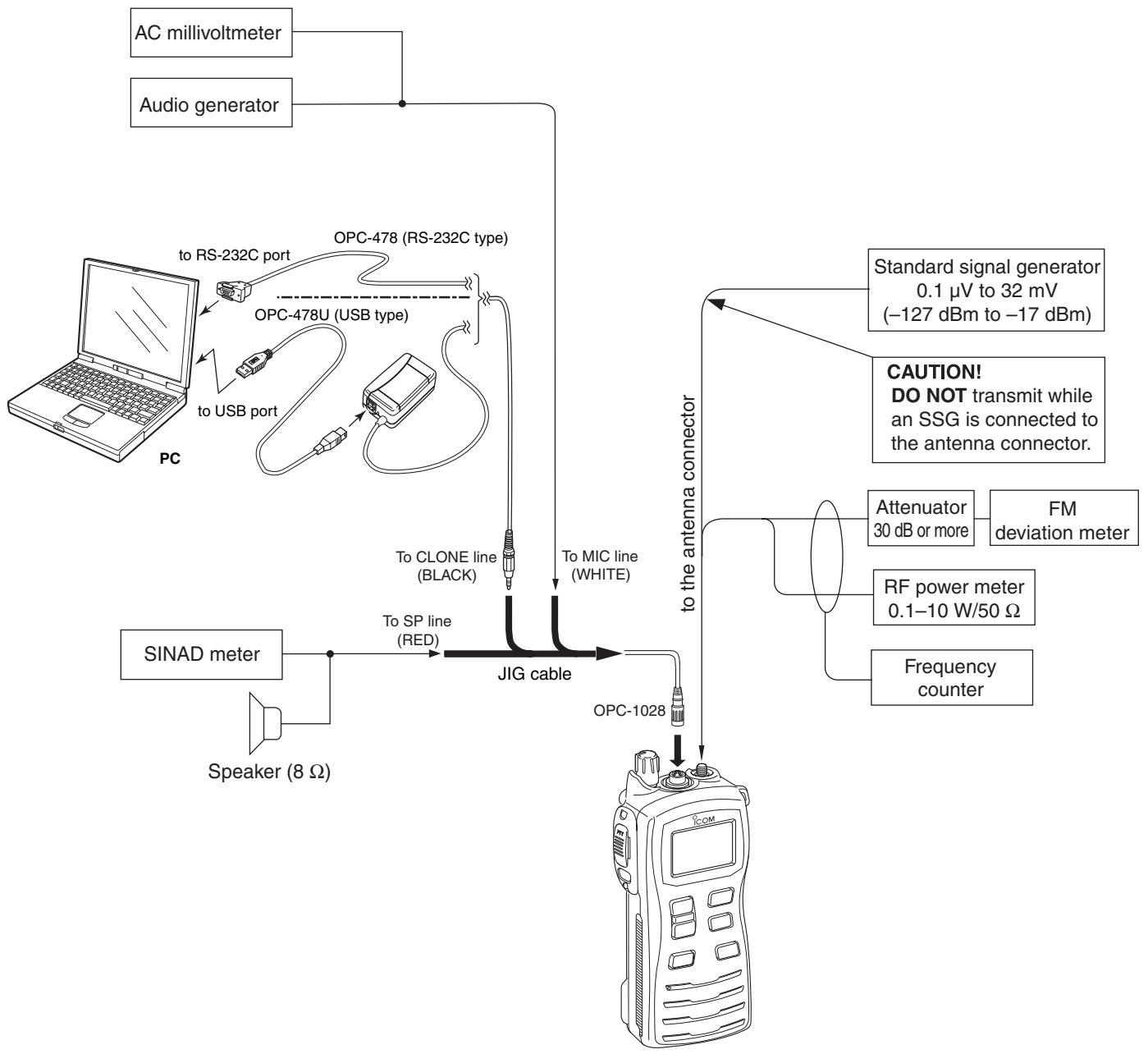

IC-M71

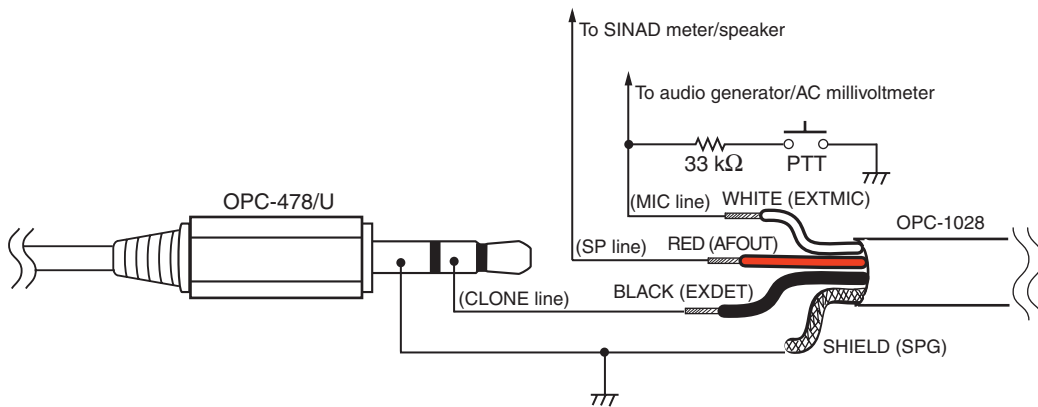

• PC SCREEN EXAMPLE

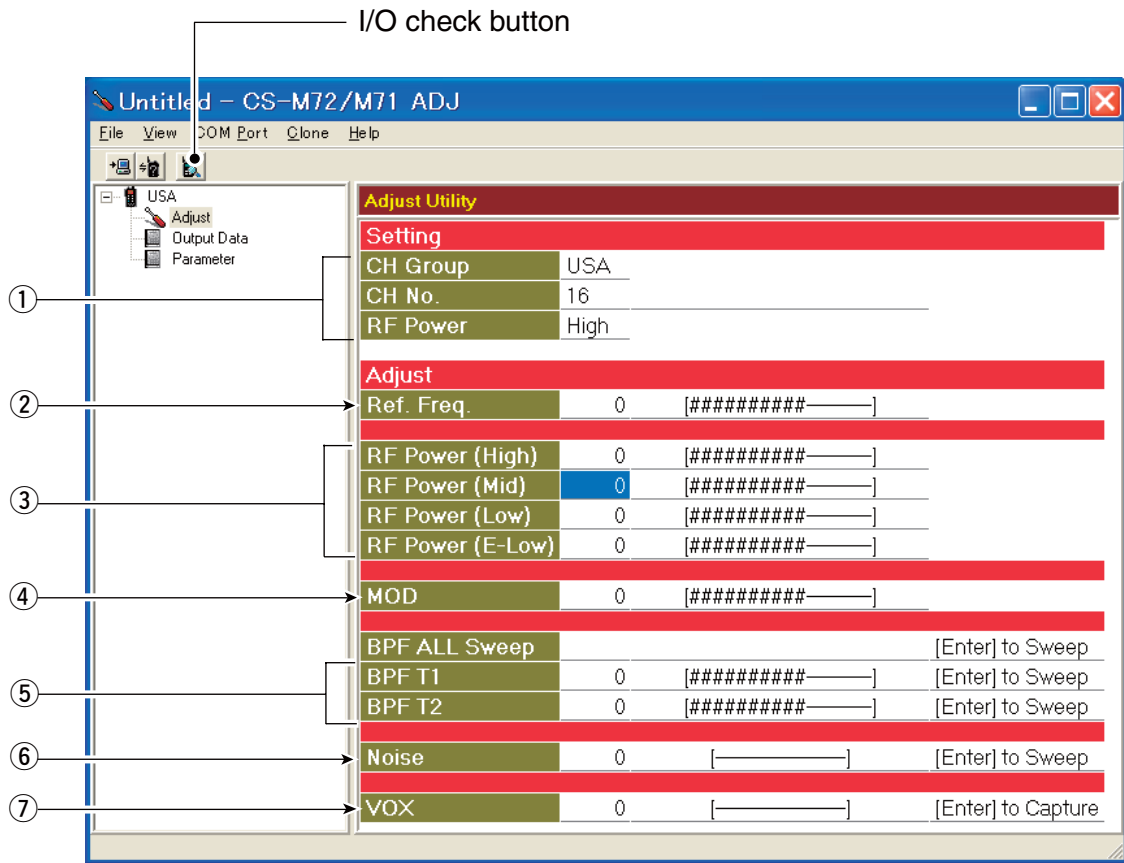

NOTE: The above screen is an example.
Each transceiver has its own specific values for each setting.

- | | |
|--------------------------|------------------------|
| ①: Adjustment condition | ⑤: Receive sensitivity |
| ②: Reference frequency | ⑥: Squelch level |
| ③: Transmit output power | ⑦: VOX |
| ④: FM deviation | |

5-2 SOFTWARE ADJUSTMENT (FREQUENCY)

Select the adjustment item with [↑] / [↓] keys, then set the value with [←] / [→] keys on the connected PC.

ADJUSTMENT	ADJUSTMENT CONDITION	MEASUREMENT		VALUE
		UNIT	OPERATION	
PLL LOCK VOLTAGE (Verify)	1 <ul style="list-style-type: none"> • Operating CH. : 16 • Receiving 	PC screen	Click the "I/O check button" on the CS-M71 ADJ's screen (see page 5-3) to open the I/O check window as below.	1.65–2.65 V (Verify)
	2 <ul style="list-style-type: none"> • Operating CH. : 16 • Connect a dummy load or RF power meter to the antenna connector. • Transmitting 			1.75–2.75 V (Verify)
REFERENCE FREQUENCY [Ref Freq]	1 <ul style="list-style-type: none"> • Operating CH. : 16 • Connect the RF power meter or a 50 Ω dummy load to the antenna connector. • Transmitting 	Top Panel	Loosely couple the frequency counter to the antenna connector.	156.8000 MHz

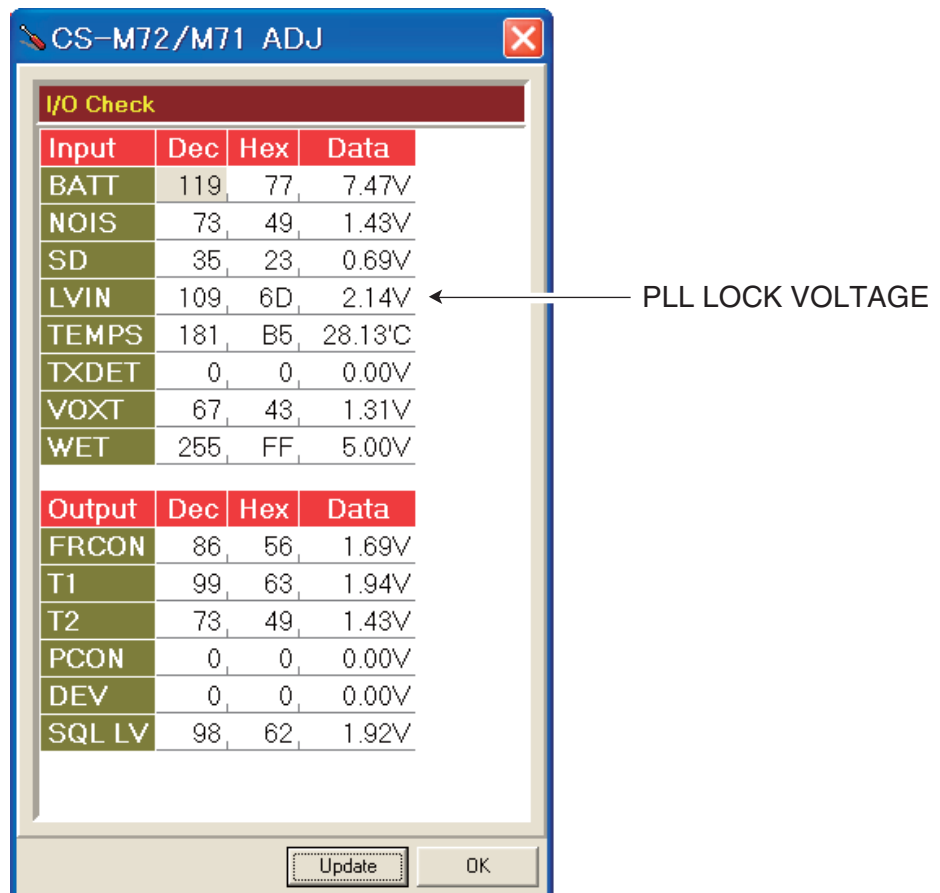

NOTE: The above screen is an example.
Each transceiver has its own specific values.

5-3 SOFTWARE ADJUSTMENT (RECEIVE AND TRANSMIT)

Select the adjustment item with [↑] / [↓] keys, then set the value with [←] / [→] keys on the connected PC.

NOTE: "RECEIVE SENSITIVITY" should be adjusted before "SQUELCH LEVEL," or "SQUELCH LEVEL" will not be adjusted properly.

ADJUSTMENT	ADJUSTMENT CONDITION	MEASUREMENT		VALUE
		UNIT	OPERATION	
RECEIVE SENSITIVITY [BPF T1]	1 <ul style="list-style-type: none"> • Operating CH.: 16 • Connect the standard signal generator to the antenna connector and set as; <ul style="list-style-type: none"> Frequency : 156.8000 MHz Level : +20 dBμ* (-87 dBm) Modulation : 1 kHz Deviation : \pm3.0 kHz • Receiving 	Top panel	Connect the distortion meter with an 8 Ω load to the [MIC/SP] jack through the JIG cable.	Minimum distortion level
[BPF T2]	2 <ul style="list-style-type: none"> • Operating CH.: 16 • Receiving 			
SQUELCH LEVEL [NOISE]	Need to adjust "SQUELCH LEVEL" after "RECEIVE SENSITIVITY" is adjusted. Otherwise, "SQUELCH LEVEL" will not be adjusted properly.			
	1 <ul style="list-style-type: none"> • Operating CH. : 16 • Connect the standard signal generator to the antenna connector and set as; <ul style="list-style-type: none"> Frequency : 156.8000 MHz Level : -4 dBμ* (-111 dBm) Modulation : 1 kHz Deviation : \pm3.0 kHz • Receiving 	Top panel	Push the [ENTER] key on the keyboard of the connected PC.	Automatic adjustment
TRANSMIT OUTPUT POWER [RF Power (High)]	1 <ul style="list-style-type: none"> • Operating CH. : 16 • RF power : High • Transmitting 	Top panel	Connect the RF power meter to the antenna connector.	5.6 W (Except [FRG], [FRG-1]) 0.75 W ([FRG], [FRG-1])
[RF Power (Middle)] (Except [FRG], [FRG-1] only)	2 <ul style="list-style-type: none"> • Operating CH. : 16 • RF power : Middle • Transmitting 			3.0 W
[RF Power (Low)]	3 <ul style="list-style-type: none"> • Operating CH. : 16 • RF power : Low • Transmitting 			0.75 W (Except [FRG], [FRG-1]) 0.45 W ([FRG], [FRG-1])
FM DEVIATION [MOD]	1 <ul style="list-style-type: none"> • Operating CH. : 16 • Set the FM deviation meter as; <ul style="list-style-type: none"> HPF : OFF LPF : 20 kHz De-emphasis : OFF Detector : (P-P)/2 • Connect the audio generator to the [MIC/SP] jack through OPC-973 and set as; <ul style="list-style-type: none"> Frequency : 1 kHz Level : 25 mV rms • Transmitting 	Top panel	Connect the FM deviation meter to the antenna connector through the attenuator.	\pm 4.30–4.40 kHz
VOX [VOX]	1 <ul style="list-style-type: none"> • Operating CH. : 16 • Set to VOX mode. (Push and hold [], then push [H/L•LOCK]) • No audio applied to the [SP MIC] jack. 	PC screen	Push the [ENTER] key on the keyboard of the connected PC.	Automatic adjustment

*The output level of the standard signal generator (SSG) is indicated as the SSG's open circuit.

SECTION 6 PARTS LIST

• IC-M71

[MAIN UNIT]

REF NO.	ORDER NO.	DESCRIPTION	M.	H/V LOCATION
IC170	1110003201	S.IC TA31136FNG (EL)	B	52/32.6
IC200	1110003780	S.IC NJM2902V-TE1	B	25.1/32.2
IC220	1110005350	S.IC NJM2870F05-TE1	B	22.8/12.3
IC260	1130011770	S.IC CD4066BPWR	B	32.7/30.8
IC280	1110001811	S.IC TA7368FG (5,ER)	B	15.9/12.4
IC340	1130012430	S.IC S-24CS64A0I-T8T1G	B	67.3/36.2
IC341	1110005771	S.IC S-80942CNMC-G9CT2G	B	72.4/39.2
IC360	1140010620	S.IC † PD78F0338GC-9EB	B	74.2/14.6
IC401	1110002420	S.IC NJM2073M-TE1	B	19.7/20.2
IC410	1130009900	S.IC FX214L2/TR [scramble] only	B	56/9.5
IC411	1110006380	S.IC LM2904PWR [scramble] only	B	34.4/18.7
IC412	1130007991	S.IC TC3W03FU (TE12L F) [scramble] only	B	63.5/8.2
IC430	1130011770	S.IC CD4066BPWR	B	16.7/36.5
IC431	1110006380	S.IC LM2904PWR	B	12/3.1
Q221	1510001090	S.TR KTA2015Y-RTK/P	B	28.4/19.4
Q223	1590003290	S.TR UNR9213J-(TX)	B	25.7/11.6
Q224	1590001190	S.TR XP6501-(TX) .AB	B	25.7/16
Q225	1520000840	S.TR KTA1664Y-RTF/P	B	28.6/13.6
Q230	1550000090	S.FET RSQ035P03TR	B	29.4/9.2
Q231	1590001190	S.TR XP6501-(TX) .AB	B	33/8.2
Q240	1590003290	S.TR UNR9213J-(TX)	B	84.7/35.9
Q250	1590003380	S.TR UNR9111J-(TX)	B	10.2/37.1
Q350	1590003270	S.TR UNR9210J-(TX)	B	78.9/37.8
Q351	1590003550	S.TR XP4313 (TX)	B	75.5/39.9
Q400	1590003290	S.TR UNR9213J-(TX)	B	13.3/33.2
Q401	1590003290	S.TR UNR9213J-(TX)	B	34.2/5.4
Q430	1590003380	S.TR UNR9111J-(TX)	B	10.1/35
Q450	1590001770	S.TR XP1213 (TX)	B	25.6/23.9
Q451	1590003290	S.TR UNR9213J-(TX)	B	27.9/23.9
Q470	1590003290	S.TR UNR9213J-(TX)	B	14.2/25.4
Q500	1590003290	S.TR UNR9213J-(TX)	B	80.1/4.6
Q540	1590003230	S.TR UNR9113J-(TX)	B	35.3/7.7
Q541	1590003290	S.TR UNR9213J-(TX) [scramble] only	B	66.8/1.3
D350	1750001180	S.DIO KDS122 RTK/P	B	81.3/37.8
D430	1790001250	S.DIO MA2S111-(TX)	B	9.1/6.1
F1170	2020001530	CER CFWLB450KFFA-B0	B	59/32.9
X170	6070000190	S.DCR CDBCB450KCAAY24-R0	B	54.1/21.5
X410	6050008910	XTL AT-38 (4.000 MHz) [scramble] only	B	
X480	6050011500	S.XTL CR-739 (9.8304 MHz)	B	81.9/29.2
R170	7030009280	S.RES ERJ2GEJ 391 X (390)	B	50.3/24.6
R171	7030007570	S.RES ERJ2GEJ 122 X (1.2 k)	B	53.0/26.2
R172	7030005000	S.RES ERJ2GEJ 471 X (470)	B	54/27.1
R173	7030005030	S.RES ERJ2GEJ 152 X (1.5 k)	B	50.7/36.9
R174	7030006610	S.RES ERJ2GEJ 394 X (390 k)	B	53.8/36.9
R175	7030005600	S.RES ERJ2GEJ 273 X (27 k)	B	54/38.1
R176	7030005120	S.RES ERJ2GEJ 102 X (1 k)	B	52.2/38.9
R201	7030005050	S.RES ERJ2GEJ 103 X (10 k)	B	28/29.1
R202	7030005090	S.RES ERJ2GEJ 104 X (100 k)	B	29.2/29.1
R203	7030003810	S.RES ERJ3GEYJ 125 V (1.2 M)	B	26.5/27.5
R204	7030005040	S.RES ERJ2GEJ 472 X (4.7 k)	B	25.2/28.9
R205	7030005210	S.RES ERJ2GEJ 822 X (8.2 k)	B	22.9/24.6
R206	7030008290	S.RES ERJ2GEJ 183 X (18 k)	B	22.4/26.9
R207	7030005600	S.RES ERJ2GEJ 273 X (27 k)	B	24.7/27.9
R212	7030005030	S.RES ERJ2GEJ 152 X (1.5 k)	B	21.5/28.3
R213	7030005070	S.RES ERJ2GEJ 683 X (68 k)	B	21.1/27
R214	7030007340	S.RES ERJ2GEJ 153 X (15 k)	B	19.8/27.7
R222	7030005050	S.RES ERJ2GEJ 103 X (10 k)	B	26.8/17.8
R223	7030005040	S.RES ERJ2GEJ 472 X (4.7 k)	B	28.4/17.6
R226	7030007290	S.RES ERJ2GEJ 222 X (2.2 k)	B	25/13.4
R227	7030005050	S.RES ERJ2GEJ 103 X (10 k)	B	31.7/13.1
R228	7030005220	S.RES ERJ2GEJ 223 X (22 k)	B	23.8/16
R230	7030005600	S.RES ERJ2GEJ 273 X (27 k)	B	30.7/6.2
R231	7030005160	S.RES ERJ2GEJ 105 X (1 M)	B	32.7/5.9
R232	7030005120	S.RES ERJ2GEJ 102 X (1 k)	B	32.7/11.4
R233	7030007290	S.RES ERJ2GEJ 222 X (2.2 k)	B	33.1/10.1
R234	7030007300	S.RES ERJ2GEJ 332 X (3.3 k)	B	34.8/9.7
R235	7030005930	S.RES ERJ3GEYF 334 V (330 k)	B	32.8/13.5
R236	7030008090	S.RES ERJ3KEF 1503 V (150 k)	B	31.8/16
R240	7030004980	S.RES ERJ2GEJ 101 X (100)	B	65.4/4.2
R240	7030008280	S.RES ERJ2GEJ 271 X (270)	B	65.4/4.2
R241	7030005010	S.RES ERJ2GEJ 681 X (680)	T	38.9/21.3

[MAIN UNIT]

REF NO.	ORDER NO.	DESCRIPTION	M.	H/V LOCATION
R243	7030007280	S.RES ERJ2GEJ 331 X (330)	B	52.8/40.9
R244	7030005010	S.RES ERJ2GEJ 681 X (680)	T	23.6/21.3
R245	7030005090	S.RES ERJ2GEJ 104 X (100 k)	B	17.7/77
R250	7030005090	S.RES ERJ2GEJ 104 X (100 k)	B	7.6/35.2
R251	7030005000	S.RES ERJ2GEJ 471 X (470)	B	12.1/36.3
R252	7030005060	S.RES ERJ2GEJ 333 X (33 k)	B	9.5/39.6
R253	7030007290	S.RES ERJ2GEJ 222 X (2.2 k)	B	21/35.9
R255	7030008300	S.RES ERJ2GEJ 184 X (180 k)	B	21.9/35.2
R256	7030008290	S.RES ERJ2GEJ 183 X (18 k)	B	20/36.2
R257	7030005040	S.RES ERJ2GEJ 472 X (4.7 k)	B	22.3/36.4
R258	7030005040	S.RES ERJ2GEJ 472 X (4.7 k)	B	24.7/35.5
R259	7030005720	S.RES ERJ2GEJ 563 X (56 k)	B	23.1/35.5
R260	7030005671	S.RES ERA3YKD 393V (39 k)	B	20.3/7.5
R261	7030009591	S.RES ERA3YED 472V (4.7 k)	B	18.9/7.5
R262	7030006601	S.RES ERA3YED 272V (2.7 k)	B	22.1/6.1
R263	7030005090	S.RES ERJ2GEJ 104 X (100 k)	B	35.7/27.6
R264	7030005090	S.RES ERJ2GEJ 104 X (100 k)	B	30.7/26.5
R265	7030005090	S.RES ERJ2GEJ 104 X (100 k)	B	35.3/36
R271	7030005720	S.RES ERJ2GEJ 563 X (56 k)	B	33.2/36.6
R272	7030005700	S.RES ERJ2GEJ 274 X (270 k)	B	31.8/36.5
R273	7030005240	S.RES ERJ2GEJ 473 X (47 k)	B	31.8/35.6
R274	7030006610	S.RES ERJ2GEJ 394 X (390 k)	B	19/24.3
R275	7030005050	S.RES ERJ2GEJ 103 X (10 k)	B	20.3/24
R276	7030008300	S.RES ERJ2GEJ 184 X (180 k)	B	17.7/24.4
R277	7030005090	S.RES ERJ2GEJ 104 X (100 k)	B	29.4/32.3
R278	7030005120	S.RES ERJ2GEJ 102 X (1 k)	B	31.2/37.7
R279	7030005030	S.RES ERJ2GEJ 152 X (1.5 k)	B	28.5/35.1
R283	7030007260	S.RES ERJ2GEJ 330 X (33)	B	19.3/9.3
R284	7030005530	S.RES ERJ2GEJ 100 X (10)	B	12.3/8.6
R286	7030005050	S.RES ERJ2GEJ 103 X (10 k)	B	17.8/28.6
R288	7030005110	S.RES ERJ2GEJ 224 X (220 k)	B	18.8/25.5
R289	7030005090	S.RES ERJ2GEJ 104 X (100 k)	B	17.5/26.3
R290	7030005050	S.RES ERJ2GEJ 103 X (10 k)	B	16.2/25.9
R300	7030005290	S.RES ERJ2GEJ 682 X (6.8 k)	B	24/25.9
R340	7030005050	S.RES ERJ2GEJ 103 X (10 k)	B	72/35.9
R341	7030005050	S.RES ERJ2GEJ 103 X (10 k)	B	72/36.8
R343	7030005050	S.RES ERJ2GEJ 103 X (10 k)	B	73.2/36.6
R350	7030005170	S.RES ERJ2GEJ 474 X (470 k)	B	52.3/2.5
R351	7030005120	S.RES ERJ2GEJ 102 X (1 k)	B	77.8/36.2
R352	7030007340	S.RES ERJ2GEJ 153 X (15 k)	B	78.6/35.3
R353	7030005120	S.RES ERJ2GEJ 102 X (1 k)	B	77.4/37.4
R354	7030005090	S.RES ERJ2GEJ 104 X (100 k)	B	76.2/37.3
R355	7030005090	S.RES ERJ2GEJ 104 X (100 k)	B	76.2/35.9
R356	7030005080	S.RES ERJ2GEJ 823 X (82 k)	B	77.4/39
R357	7030005240	S.RES ERJ2GEJ 473 X (47 k)	B	75/38.2
R358	7030005050	S.RES ERJ2GEJ 103 X (10 k)	B	61.8/39.5
R358	7030010040	S.RES ERJ2GEJ-JPW	B	61.8/39.5
R359	7030005090	S.RES ERJ2GEJ 104 X (100 k)	B	79.7/36.2
R375	7030005290	S.RES ERJ2GEJ 682 X (6.8 k)	B	20/39.7
R376	7030005090	S.RES ERJ2GEJ 104 X (100 k)	B	24/26.9
R377	7030005080	S.RES ERJ2GEJ 823 X (82 k)	B	23.1/27.9
R378	7030005080	S.RES ERJ2GEJ 823 X (82 k)	B	21.3/29.3
R379	7030005080	S.RES ERJ2GEJ 823 X (82 k)	B	19.9/30.8
R393	7030005090	S.RES ERJ2GEJ 104 X (100 k)	B	32.6/26
R394	7030005090	S.RES ERJ2GEJ 104 X (100 k)	B	34.1/36
R395	7030005090	S.RES ERJ2GEJ 104 X (100 k)	B	
R400	7030005090	S.RES ERJ2GEJ 104 X (100 k)	B	34.7/26.5
R401	7030005050	S.RES ERJ2GEJ 103 X (10 k)	B	15.2/31.3
R402	7030005530	S.RES ERJ2GEJ 100 X (10)	B	16.1/24.1
R403	7030005170	S.RES ERJ2GEJ 474 X (470 k)	B	15.2/18.8
R410	7030005050	S.RES ERJ2GEJ 103 X (10 k)	B	16.4/31.8
R411	7030005720	S.RES ERJ2GEJ 563 X (56 k) [scramble] only	B	32.7/23
R412	7030005090	S.RES ERJ2GEJ 104 X (100 k) [scramble] only	B	34.3/23
R413	7030008290	S.RES ERJ2GEJ 183 X (18 k) [scramble] only	B	32/20.2
R414	7030007300	S.RES ERJ2GEJ 332 X (3.3 k) [scramble] only	B	34.6/13.5
R415	7030005090	S.RES ERJ2GEJ 104 X (100 k) [scramble] only	B	34.6/14.4
R416	7030005160	S.RES ERJ2GEJ 105 X (1 M) [scramble] only	B	32/18.6
R417	7030005120	S.RES ERJ2GEJ 102 X (1 k) [scramble] only	B	63.8/4.2
R419	7030005040	S.RES ERJ2GEJ 472 X (4.7 k) [scramble] only	B	62.9/5.1
R430	7030005090	S.RES ERJ2GEJ 104 X (100 k)	B	36.8/20
R431	7030005090	S.RES ERJ2GEJ 104 X (100 k)	B	10.2/33
R432	7030005090	S.RES ERJ2GEJ 104 X (100 k)	B	11.7/33.9
R433	7030007340	S.RES ERJ2GEJ 153 X (15 k)	B	14.8/32.2
			B	11.8/6.8

M.=Mounted side (T: Mounted on the Top side, B: Mounted on the Bottom side)
S.=Surface mount

[MAIN UNIT]

REF NO.	ORDER NO.	DESCRIPTION	M.	H/V LOCATION
R434	7030005230	S.RES ERJ2GEJ 334 X (330 k)	B	10.5/5.5
R435	7030008400	S.RES ERJ2GEJ 182 X (1.8 k)	B	6.7/2.7
R436	7030006610	S.RES ERJ2GEJ 394 X (390 k)	B	7.7/2.7
R437	7030005220	S.RES ERJ2GEJ 223 X (22 k)	B	7.7/4.3
R438	7030007310	S.RES ERJ2GEJ 155 X (1.5 M)	B	7.7/5.6
R439	7030005040	S.RES ERJ2GEJ 472 X (4.7 k)	B	13.8/6.8
R440	7030005210	S.RES ERJ2GEJ 822 X (8.2 k)	B	13.7/5.5
R441	7030005090	S.RES ERJ2GEJ 104 X (100 k)	B	16.3/6.7
R442	7030005040	S.RES ERJ2GEJ 472 X (4.7 k)	B	12.1/5.5
R450	7030008290	S.RES ERJ2GEJ 183 X (18 k)	B	26.4/25.8
R451	7030005210	S.RES ERJ2GEJ 822 X (8.2 k)	B	28/25.4
R452	7030008410	S.RES ERJ2GEJ 392 X (3.9 k)	B	29.3/25.4
R453	7030005120	S.RES ERJ2GEJ 102 X (1 k)	B	28/26.3
R454	7030005170	S.RES ERJ2GEJ 474 X (470 k)	B	29.2/28.2
R481	7030005160	S.RES ERJ2GEJ 105 X (1 M)	B	85/25.8
R483	7030005530	S.RES ERJ2GEJ 100 X (10)	B	85/27.4
R489	7030005050	S.RES ERJ2GEJ 103 X (10 k)	B	72.9/25.3
R491	7030005050	S.RES ERJ2GEJ 103 X (10 k)	B	78.3/24.9
R493	7030005050	S.RES ERJ2GEJ 103 X (10 k)	B	76.4/25.5
R495	7030005050	S.RES ERJ2GEJ 103 X (10 k)	B	78.3/23.9
R496	7030005050	S.RES ERJ2GEJ 103 X (10 k)	B	79.5/22.7
R497	7030005050	S.RES ERJ2GEJ 103 X (10 k)	B	80.5/21.5
R498	7030009150	S.RES ERJ2GEJ 824 X (820 k)	B	79.3/6.3
R499	7030007310	S.RES ERJ2GEJ 155 X (1.5 M)	B	80.9/7.1
R500	7030007060	S.RES ERJ2GEJ 684X (680 k)	B	82/5.9
R501	7030008300	S.RES ERJ2GEJ 184 X (180 k)	B	81.1/5.9
R502	7030010040	S.RES ERJ2GEJ-JPW [scramble] only	B	72.9/26.2
R505	7030005090	S.RES ERJ2GEJ 104 X (100 k)	B	64.8/18.6
R512	7030005120	S.RES ERJ2GEJ 102 X (1 k)	B	66/3
R520	7030010040	S.RES ERJ2GEJ-JPW [scramble] only	B	10.4/38.9
R521	7030009140	S.RES ERJ2GEJ 272 X (2.7 k)	B	11.3/38.9
R540	7030005700	S.RES ERJ2GEJ 274 X (270 k)	B	27.2/10.2
R541	7030005050	S.RES ERJ2GEJ 103 X (10 k)	B	27.8/6.9
C160	4030018240	S.CER ECJ0EB1E562K	B	50.3/23
C170	4030017460	S.CER ECJ0EB1E102K	B	51.3/38.1
C171	4030017680	S.CER ECJ0EC1H820J	B	52.3/27.9
C174	4030017460	S.CER ECJ0EB1E102K	B	54.6/28.3
C175	4030017460	S.CER ECJ0EB1E102K	B	56.1/26.3
C176	4030017460	S.CER ECJ0EB1E102K	B	54.9/27.1
C177	4030016930	S.CER ECJ0EB1A104K	B	50.1/38.9
C178	4030018890	S.CER ECJ0EB0J224K	B	50.1/37.9
C179	4030017450	S.CER ECJ0EB1E271K	B	53.1/38.1
C180	4030017450	S.CER ECJ0EB1E271K	B	54.9/38.1
C181	4030016930	S.CER ECJ0EB1A104K	B	52.2/37.3
C200	4030016790	S.CER ECJ0EB1C103K	B	19.9/33.5
C202	4030016930	S.CER ECJ0EB1A104K	B	22.4/25.9
C205	4030016960	S.CER ECJ0EB1C183K	B	19.8/28.6
C206	4030017460	S.CER ECJ0EB1E102K	B	19.8/26.8
C207	4030016930	S.CER ECJ0EB1A104K	B	21.1/25.4
C222	4030016790	S.CER ECJ0EB1C103K	B	28.3/16.7
C224	4550006250	S.TAN TEESVA 1A 106M8R	B	28.3/21.7
C225	4030018890	S.CER ECJ0EB0J224K	B	23.4/17.3
C226	4030016790	S.CER ECJ0EB1C103K	B	21.6/14.5
C227	4550006250	S.TAN TEESVA 1A 106M8R	B	20.8/16.1
C228	4030017460	S.CER ECJ0EB1E102K	B	23.2/14.5
C229	4030017460	S.CER ECJ0EB1E102K	B	26.2/6.7
C230	4550006470	S.TAN TEESVB2 1D 106M8R	B	23.8/8.9
C231	4030018870	S.CER ECJ0EF0J105Z	B	31.8/5.5
C233	4030016790	S.CER ECJ0EB1C103K	B	30.7/16.6
C240	4030017460	S.CER ECJ0EB1E102K	B	27.2/8.6
C250	4030016930	S.CER ECJ0EB1A104K	B	6.5/36.3
C251	4550006250	S.TAN TEESVA 1A 106M8R	B	12.9/39.2
C252	4030017460	S.CER ECJ0EB1E102K	B	10.4/40.5
C254	4030016790	S.CER ECJ0EB1C103K	B	21/37.5
C257	4030016790	S.CER ECJ0EB1C103K	B	19.9/37.8
C260	4030018910	S.CER C1608 JB 0J 475K-T	B	24/6.6
C261	4030016930	S.CER ECJ0EB1A104K	B	35.3/25.6
C262	4030016790	S.CER ECJ0EB1C103K	B	36.3/36
C263	4030016790	S.CER ECJ0EB1C103K	B	17.7/23.5
C264	4030017770	S.CER ECJ0EB1E332K	B	32.3/37.9
C265	4030017420	S.CER ECJ0EC1H470J	B	29.4/33.9
C266	4030016950	S.CER ECJ0EB1A473K	B	30.3/37.7
C267	4030018860	S.CER ECJ0EB0J105K	B	30/36.5
C280	4030018860	S.CER ECJ0EB0J105K	B	16.1/28.4
C282	4550007080	S.TAN TEESVA 1C 106M8R	B	11.9/11.6
C283	4030016930	S.CER ECJ0EB1A104K	B	15/16.7
C284	4030017460	S.CER ECJ0EB1E102K	B	15/17.6
C285	4030016930	S.CER ECJ0EB1A104K	B	19.2/29.5
C286	4550006250	S.TAN TEESVA 1A 106M8R	B	19.9/12.3
C287	4030017700	S.CER ECJ0EC1H151J	B	15.5/8.1
C288	4030016950	S.CER ECJ0EB1A473K	B	10.3/9.3
C289	4510009010	S.ELE EEE1AA221P	B	68.6/29.9
C300	4030017770	S.CER ECJ0EB1E332K	B	23.9/24.6
C340	4030016790	S.CER ECJ0EB1C103K	B	71.8/34.6
C341	4030017030	S.CER ECJ0EB1A273K	B	69.9/39
C350	4030017460	S.CER ECJ0EB1E102K	B	53.5/2
C351	4030017420	S.CER ECJ0EC1H470J	B	77.4/35

[MAIN UNIT]

REF NO.	ORDER NO.	DESCRIPTION	M.	H/V LOCATION
C352	4030017420	S.CER ECJ0EC1H470J	B	78.7/34.1
C376	4030016930	S.CER ECJ0EB1A104K	B	18.7/40.8
C377	4030017740	S.CER ECJ0EB1E821K	B	23.6/28.9
C378	4030017780	S.CER ECJ0EB1E472K	B	20.8/30.7
C379	4030017500	S.CER ECJ0EC1H560J	B	20/32.2
C401	4030018870	S.CER ECJ0EF0J105Z	B	17.3/16.8
C402	4030018870	S.CER ECJ0EF0J105Z	B	17.7/31.8
C403	4550006250	S.TAN TEESVA 1A 106M8R	B	25/19.8
C404	4030016790	S.CER ECJ0EB1C103K	B	23/23.4
C405	4030016930	S.CER ECJ0EB1A104K	B	15.2/20.4
C410	4030018860	S.CER ECJ0EB0J105K	[scramble] only	B 49.6/8
C411	4030018860	S.CER ECJ0EB0J105K	[scramble] only	B 49.6/11.2
C412	4030018860	S.CER ECJ0EB0J105K	[scramble] only	B 51.3/15.3
C413	4030016930	S.CER ECJ0EB1A104K	[scramble] only	B 32/21.8
C414	4030016930	S.CER ECJ0EB1A104K	[scramble] only	B 36/23
C415	4030018860	S.CER ECJ0EB0J105K	[scramble] only	B 36.8/16.8
C416	4030018860	S.CER ECJ0EB0J105K	[scramble] only	B 36.8/18.4
C417	4030016790	S.CER ECJ0EB1C103K	[scramble] only	B 36.8/21.6
C418	4030016790	S.CER ECJ0EB1C103K	[scramble] only	B 31.1/18.6
C419	4030016930	S.CER ECJ0EB1A104K	[scramble] only	B 55.6/16.3
C420	4030017650	S.CER ECJ0EC1H270J	[scramble] only	B 67.1/4.3
C421	4030017650	S.CER ECJ0EC1H270J	[scramble] only	B 62.2/4.2
C422	4030017690	S.CER ECJ0EC1H121J	[scramble] only	B 62.3/11.6
C423	4030016930	S.CER ECJ0EB1A104K	[scramble] only	B 64.9/5.1
C424	4030018860	S.CER ECJ0EB0J105K	[scramble] only	B 49.6/9.6
C425	4030018860	S.CER ECJ0EB0J105K	[scramble] only	B 49.8/4.8
C430	4030018860	S.CER ECJ0EB0J105K	[scramble] only	B 12.5/35.1
C431	4030018860	S.CER ECJ0EB0J105K	[scramble] only	B 14.8/40.8
C432	4030016930	S.CER ECJ0EB1A104K	B	8.9/34
C433	4030017460	S.CER ECJ0EB1E102K	B	12/31.8
C434	4030016960	S.CER ECJ0EB1C183K	B	12.8/6.8
C435	4030016960	S.CER ECJ0EB1C183K	B	10.5/7.5
C436	4030017730	S.CER ECJ0EB1E471K	B	10.5/6.5
C437	4030017460	S.CER ECJ0EB1E102K	B	7.7/6.6
C438	4030016930	S.CER ECJ0EB1A104K	B	14.8/6.8
C439	4030016930	S.CER ECJ0EB1A104K	B	6.7/4.3
C450	4030018860	S.CER ECJ0EB0J105K	B	28/27.5
C451	4030018860	S.CER ECJ0EB0J105K	B	29.3/27
C482	4030017400	S.CER ECJ0EC1H220J	B	85.9/25.8
C483	4030017400	S.CER ECJ0EC1H220J	B	85/24.2
C488	4550006250	S.TAN TEESVA 1A 106M8R	B	65/21.6
C489	4030016790	S.CER ECJ0EB1C103K	B	66.6/21.8
C490	4030016790	S.CER ECJ0EB1C103K	B	66.5/24.4
C491	4030016950	S.CER ECJ0EB1A473K	B	85.3/22.9
C492	4030017460	S.CER ECJ0EB1E102K	B	85.6/21.1
C493	4030016950	S.CER ECJ0EB1A473K	B	85.5/19
C494	4030016950	S.CER ECJ0EB1A473K	B	85.6/15.1
C495	4030017040	S.CER ECJ0EB1A333K	B	85.9/16.9
C496	4030016950	S.CER ECJ0EB1A473K	B	85.5/18.1
C497	4030016950	S.CER ECJ0EB1A473K	B	85.2/7.9
C498	4030016950	S.CER ECJ0EB1A473K	B	85.2/6.2
C499	4030016950	S.CER ECJ0EB1A473K	B	84.3/6
C500	4030016930	S.CER ECJ0EB1A104K	B	83.4/6.4
C502	4030018900	S.CER ECJ0EB0J474K	B	81.7/8.2
C503	4030018900	S.CER ECJ0EB0J474K	B	78.5/4.7
C504	4030018900	S.CER ECJ0EB0J474K	B	77.6/4.7
C505	4030018900	S.CER ECJ0EB0J474K	B	82.3/9.4
J100	6510025130	S.CNR 30P9.0-JMCS-G-B-TF (N)	B	61.3/20.3
J251	6510021900	S.CNR BM02B-ASRS-TF	T	6.6/3
J260	6510022690	S.CNR 06FLT-SM1-TB	B	65.3/40.1
J300	6510025140	S.CNR 10FLT-SM1-TB	B	76.6/29.7
DS240	5040003010	S.LED SML-A12WT	T	63.5/2.1
DS241	5040003010	S.LED SML-A12WT	T	73.5/2.1
DS242	5040002310	S.LED SML-311YTT86	T	38.9/12.3
DS243	5040002310	S.LED SML-311YTT86	T	38.9/30.3
DS250	5040003010	S.LED SML-A12WT	T	63.5/40.4
DS251	5040003010	S.LED SML-A12WT	T	73.5/40.4
DS252	5040002310	S.LED SML-311YTT86	T	23.6/11.8
DS253	5040002310	S.LED SML-311YTT86	T	23.6/30.8
DS480	5030002910	LCD L5-0213TVM		
MC250	7700002480	MIC SKB-2746 LPC		
EP360	8930069010	LCT SRCN-2905-SP-N-W		

M.=Mounted side (T: Mounted on the Top side, B: Mounted on the Bottom side)
S.=Surface mount

[RF UNIT]

REF NO.	ORDER NO.	DESCRIPTION	M.	H/V LOCATION
IC1	1130007610	S.IC ‡ PD3140GS-E1 (DS8)	T	8.5/32.1
IC50	1120002830	S.IC NJM2125F-TE1	B	27.3/25.1
IC190	1190000350	S.IC M62363FP-650C	T	25.4/23.8
Q3	1560000541	S.FET 2SK880-Y (T5RICOM F)	T	23/36.2
Q20	1590003290	S.TR UNR9213J-(TX)	B	17.5/31.7
Q21	1530002920	S.TR 2SC4226-T1 R25	B	17.3/27.3
Q22	1530002920	S.TR 2SC4226-T1 R25	B	21.7/25.5
Q23	1530002381	S.TR 2SC4215-Y (TE85R F)	B	13/30.4
Q24	1530002381	S.TR 2SC4215-Y (TE85R F)	B	11.1/25.3
Q25	1530002381	S.TR 2SC4215-Y (TE85R F)	B	11.2/33.8
Q50	1530003421	S.TR 2SC5110-O (TE85R F)	T	4.3/2.2
Q53	1560001240	S.FET RD01MUS1	T	8.3/8.2
Q53	1560001241	S.FET RD01MUS1-T113	T	8.3/8.2
Q54	1560001230	S.FET RD07MVS1	T	18.1/7.7
Q90	1580000751	S.FET 3SK294 (TE85L F)	T	18.7/16.2
Q100	1590003290	S.TR UNR9213J-(TX)	B	29.1/20.9
Q150	1580000731	S.FET 3SK293 (TE85L F)	B	10/17.3
Q151	1530002601	S.TR 2SC4215-O (TE85R F)	B	7.3/28.3
Q152	1560000841	S.FET 2SK1829 (TE85R F)	B	21.9/15.3
Q220	1510001090	S.TR KTA2015Y-RTK/P	T	18.4/25.7
Q222	1510001090	S.TR KTA2015Y-RTK/P	T	28.9/16.7
Q351	1590003230	S.TR UNR9113J-(TX)	B	25.5/27.9
Q480	1550000090	S.FET RSQ035P03TR	B	3.7/3.4
D1	1750000771	S.VCP HVC376BTFR-FE	B	2.2/39.8
D20	1790001260	S.DIO MA2S077-(TX)	B	18.6/34.2
D21	1790001260	S.DIO MA2S077-(TX)	B	16.8/33.9
D22	1750000711	S.VCP HVC350BTFR-FE	B	21.9/27.5
D23	1750000711	S.VCP HVC350BTFR-FE	B	21.9/28.8
D50	1790001260	S.DIO MA2S077-(TX)	T	6.6/17.9
D51	1790001260	S.DIO MA2S077-(TX)	T	6.5/20.1
D52	1750000581	S.DIO 1SV307 (TPH3 F)	T	27.2/6.4
D80	1790001670	S.DIO RB706F-40T106	B	25.4/2.9
D90	1750000581	S.DIO 1SV307 (TPH3 F)	B	27.5/7.6
D91	1790001670	S.DIO RB706F-40T106	T	24.7/10.5
D92	1750000711	S.VCP HVC350BTFR-FE	B	30.6/12.4
D93	1750000711	S.VCP HVC350BTFR-FE	B	25.9/18.1
D94	1790001621	S.DIO 1SV308 (TPL3 F)	B	31.9/9.5
D130	1750000711	S.VCP HVC350BTFR-FE	B	15.8/17
D131	1750000711	S.VCP HVC350BTFR-FE	B	14.4/18.8
D132	1790001250	S.DIO MA2S111-(TX)	B	25.4/16.9
D353	1790001260	S.DIO MA2S077-(TX)	B	29.9/8.6
FI150	2030000350	MLH 21R15AB (FL-368)		
FI151	2030000270	MLH FL-363 (21.7 MHz)		
X1	6050011740	S.XTL CR-766 (21.250 MHz)	B	6.3/36.8
L1	6200008070	S.COL MLF1608E 6R8K 6.8U	T	3.8/37.6
L20	6200011021	S.COL ELJRF 82NJFB	B	11.5/36.7
L21	6200003711	S.COL NLV25T-2R7J	B	21.2/35.7
L22	6200011410	S.COL C2520C-82NG-A	B	20.8/31
L23	6200011031	S.COL ELJRF R10JFB	B	12.9/32.3
L24	6200011031	S.COL ELJRF R10JFB	B	12.1/27.3
L25	6200011031	S.COL ELJRF R10JFB	B	13.2/33.7
L26	6200009151	S.COL ELJRE 82NJFA	T	7.6/15
L50	6200006981	S.COL ELJRE R10GFA	T	6.3/3.2
L51	6200007001	S.COL ELJRE 82NGFA	T	7.6/4.2
L53	6200007690	S.COL LQW2BHN18NJ03L	T	11.9/12.4
L55	6200009240	S.COL 0.20-1.0-TTL 31N	T	20.7/12.5
L56	6200010640	S.COL 0.26-1.0-3TL 8.5N	T	20.3/2.9
L57	6200008540	S.COL 0.26-0.9-6TR 19N	T	23.6/2.4
L58	6200003711	S.COL NLV25T-2R7J	T	28.1/10.6
L80	6200008280	S.COL 0.30-1.7-TTL 50N	T	23.9/7.8
L81	6200009800	S.COL 0.26-1.1-TTR 30N	B	29.5/5.4
L82	6200008580	S.COL 0.30-1.4-6TL 32N	B	32.7/5.2
L90	6200008280	S.COL 0.30-1.7-TTL 50N	B	24.2/6.8
L91	6200010991	S.COL ELJRF 47NJFB	B	24.8/9.1
L92	6200007750	S.COL LQW2BHN56NJ03L	B	24/10.6
L93	6200007750	S.COL LQW2BHN56NJ03L	B	28.9/11.8
L95	6200003960	S.COL MLF1608A 1R0K-T	B	21.6/20.5
L96	6200007750	S.COL LQW2BHN56NJ03L	B	17.7/19.4
L97	6200007750	S.COL LQW2BHN56NJ03L	B	13.8/14.4
L98	6200003680	S.COL LQH31MNR82M03L	B	8.7/19.8
L99	6200002690	S.COL MLF1608A 1R0M-T	B	32.4/12.3
R1	7510001661	S.TMR NTCG16 4LH 473JT	B	6.1/31.9
R2	7030010080	S.RES ERJ2RHD 104 X (100 k)	B	6.9/30.6
R3	7030005050	S.RES ERJ2GEJ 103 X (10 k)	B	4.3/31.7
R4	7030005240	S.RES ERJ2GEJ 473 X (47 k)	B	3.8/36.6
R5	7030007280	S.RES ERJ2GEJ 331 X (330)	T	8.9/37.2
R6	7030005120	S.RES ERJ2GEJ 102 X (1 k)	T	18.4/28.6
R7	7030005240	S.RES ERJ2GEJ 473 X (47 k)	T	18/29.8

[RF UNIT]

REF NO.	ORDER NO.	DESCRIPTION	M.	H/V LOCATION
R8	7030005120	S.RES ERJ2GEJ 102 X (1 k)	T	13.4/33.2
R9	7030005530	S.RES ERJ2GEJ 100 X (10)	T	16.6/34.7
R10	7030009140	S.RES ERJ2GEJ 272 X (2.7 k)	T	18.7/35.1
R11	7030005120	S.RES ERJ2GEJ 102 X (1 k)	T	25.3/37
R12	7030005050	S.RES ERJ2GEJ 103 X (10 k)	T	21.2/36.5
R13	7030005210	S.RES ERJ2GEJ 822 X (8.2 k)	T	24.3/34.1
R20	7030004980	S.RES ERJ2GEJ 101 X (100)	B	12.8/35.4
R22	7030007290	S.RES ERJ2GEJ 222 X (2.2 k)	T	19.7/35.1
R23	7030005120	S.RES ERJ2GEJ 102 X (1 k)	B	18.8/33.1
R24	7030005090	S.RES ERJ2GEJ 104 X (100 k)	B	15.7/34.3
R25	7030005090	S.RES ERJ2GEJ 104 X (100 k)	B	16/35.6
R26	7030008010	S.RES ERJ2GEJ 123 X (12 k)	B	17.7/29.1
R27	7030008010	S.RES ERJ2GEJ 123 X (12 k)	B	19.7/27.1
R28	7030009160	S.RES ERJ2GEJ 181 X (180)	B	18.5/25.6
R29	7030005000	S.RES ERJ2GEJ 471 X (470)	B	15.6/26.1
R30	7030005070	S.RES ERJ2GEJ 683 X (68 k)	B	15.7/30.3
R31	7030005000	S.RES ERJ2GEJ 471 X (470)	B	14.1/32.1
R32	7030009280	S.RES ERJ2GEJ 391 X	B	13.4/28.2
R33	7030007350	S.RES ERJ2GEJ 393 X (39 k)	B	10.8/28.3
R34	7030005000	S.RES ERJ2GEJ 471 X (470)	B	14.1/33.7
R35	7030005070	S.RES ERJ2GEJ 683 X (68 k)	B	10.8/32.1
R36	7030005120	S.RES ERJ2GEJ 102 X (1 k)	T	16.6/29
R50	7030005120	S.RES ERJ2GEJ 102 X (1 k)	T	8.1/25.6
R52	7030005040	S.RES ERJ2GEJ 472 X (4.7 k)	T	4.6/11
R53	7030004980	S.RES ERJ2GEJ 101 X (100)	T	5.8/10.5
R54	7030005530	S.RES ERJ2GEJ 100 X (10)	T	5.2/6.1
R55	7030007300	S.RES ERJ2GEJ 332 X (3.3 k)	T	5.2/5
R56	7030005000	S.RES ERJ2GEJ 471 X (470)	T	3.3/4
R57	7030005590	S.RES ERJ2GEJ 680 X (68)	T	2.4/1.2
R65	7030005100	S.RES ERJ2GEJ 154 X (150 k)	B	27.9/27.8
R66	7030005240	S.RES ERJ2GEJ 473 X (47 k)	B	29.5/27.6
R67	7030005090	S.RES ERJ2GEJ 104 X (100 k)	B	26.5/22.7
R68	7030004980	S.RES ERJ2GEJ 101 X (100)	B	27.4/22.7
R69	7030007340	S.RES ERJ2GEJ 153 X (15 k)	T	11/2.8
R70	7030005600	S.RES ERJ2GEJ 273 X (27 k)	T	10.7/4.2
R71	7030004970	S.RES ERJ2GEJ 470 X (47)	T	9.1/4.3
R72	7030005710	S.RES ERJ2GEJ 121 X (120)	T	12.4/14
R73	7030005120	S.RES ERJ2GEJ 102 X (1 k)	T	12.2/2.4
R74	7030008010	S.RES ERJ2GEJ 123 X (12 k)	T	13.4/2.5
R75	7030005580	S.RES ERJ2GEJ 560 X (56)	T	14.2/4.4
R76	7030000280	S.RES MCR10EZJH 150 (151)	T	29/13.9
R80	7030003670	S.RES ERJ3GEJY 823 V (82 k)	T	29/4.8
R81	7030005220	S.RES ERJ2GEJ 223 X (22 k)	T	22/17.2
R82	7030005050	S.RES ERJ2GEJ 103 X (10 k)	T	21.7/16
R85	7030005110	S.RES ERJ2GEJ 224 X (220 k)	T	32.5/13.2
R90	7030005710	S.RES ERJ2GEJ 121 X (120)	B	32.7/10.5
R91	7030005110	S.RES ERJ2GEJ 224 X (220 k)	B	29.9/17.6
R93	7030005050	S.RES ERJ2GEJ 103 X (10 k)	B	28.8/19.4
R94	7030005110	S.RES ERJ2GEJ 224 X (220 k)	B	27.5/18.1
R95	7030005090	S.RES ERJ2GEJ 104 X (100 k)	B	22.3/18.6
R96	7030005700	S.RES ERJ2GEJ 274 X (270 k)	B	20.5/16.6
R97	7030005000	S.RES ERJ2GEJ 471 X (470)	B	20.8/18.5
R98	7030005050	S.RES ERJ2GEJ 103 X (10 k)	B	22.8/19.8
R99	7030005170	S.RES ERJ2GEJ 474 X (470 k)	B	23.7/16.7
R100	7030010040	S.RES ERJ2GEJ-JPW	T	4.9/9.8
R101	7030009290	S.RES ERJ2GEJ 562 X (5.6 k)	B	22.5/13.6
R102	7030005240	S.RES ERJ2GEJ 473 X (47 k)	B	20.5/14
R103	7030005050	S.RES ERJ2GEJ 103 X (10 k)	B	21.7/17.3
R104	7030009270	S.RES ERJ2GEJ 821 X (820)	B	16.2/15.3
R105	7030005110	S.RES ERJ2GEJ 224 X (220 k)	B	16.2/20.3
R106	7030005050	S.RES ERJ2GEJ 103 X (10 k)	B	16.5/21.5
R107	7030005110	S.RES ERJ2GEJ 224 X (220 k)	B	15.3/20.3
R108	7030010040	S.RES ERJ2GEJ-JPW	B	12/19.3
R109	7030005530	S.RES ERJ2GEJ 100 X (10)	B	9.2/21.6
R110	7030008400	S.RES ERJ2GEJ 182 X (1.8 k)	B	7.2/15.5
R111	7030005090	S.RES ERJ2GEJ 104 X (100 k)	B	11.7/15.6
R115	7030008290	S.RES ERJ2GEJ 183 X (18 k)	B	8.9/15.4
R120	7030007290	S.RES ERJ2GEJ 222 X (2.2 k)	T	8.2/20.2
R121	7030007350	S.RES ERJ2GEJ 393 X (39 k)	B	9.3/14.2
R122	7030005700	S.RES ERJ2GEJ 274 X (270 k)	B	10.2/14.2
R152	7030004980	S.RES ERJ2GEJ 101 X (100)	B	2.7/12.2
R153	7030005030	S.RES ERJ2GEJ 152 X (1.5 k)	B	2.3/28.4
R154	7030005090	S.RES ERJ2GEJ 104 X (100 k)	B	5.6/29
R155	7030005030	S.RES ERJ2GEJ 152 X (1.5 k)	B	6.9/25.2
R156	7030005000	S.RES ERJ2GEJ 471 X (470)	B	7.5/26.4
R192	7030009280	S.RES ERJ2GEJ 391 X	T	23.4/32.6
R193	7030005000	S.RES ERJ2GEJ 471 X (470)	T	20/28.8
R194	7030005090	S.RES ERJ2GEJ 104 X (100 k)	T	25.4/29.6
R220	7030005050	S.RES ERJ2GEJ 103 X (10 k)	T	20.1/24.3
R221	7030005040	S.RES ERJ2GEJ 472 X (4.7 k)	T	19.2/23.5
R224	7030005050	S.RES ERJ2GEJ 103 X (10 k)	T	27/17.6
R225	7030005040	S.RES ERJ2GEJ 472 X (4.7 k)	T	24.9/17.5
R230	7030005070	S.RES ERJ2GEJ 683 X (68 k)	B	29.4/24.8
R380	7030003580	S.RES ERJ3GEJY 153 V (15 k)	T	22.6/10.5
R381	7030005050	S.RES ERJ2GEJ 103 X (10 k)	B	25.5/21.8
R382	7030009140	S.RES ERJ2GEJ 272 X (2.7 k)	B	26.3/19.3
R383	7030008010	S.RES ERJ2GEJ 123 X (12 k)	B	25.5/20.2
R384	7030007290	S.RES ERJ2GEJ 222 X (2.2 k)	B	25.1/24.5
R386	7030005050	S.RES ERJ2GEJ 103 X (10 k)	B	25.9/31.3
R510	7030005700	S.RES ERJ2GEJ 274 X (270 k)	B	3.9/6.4

M.=Mounted side (T: Mounted on the Top side, B: Mounted on the Bottom side)
S.=Surface mount

[RF UNIT]

REF NO.	ORDER NO.	DESCRIPTION	M.	H/V LOCATION
R511	7030005050	S.RES ERJ2GEJ 103 X (10 k)	B	3.5/7.7
C1	4030016930	S.CER ECJ0EB1A104K	B	6/30.6
C2	4030016790	S.CER ECJ0EB1C103K	B	3.7/33.1
C3	4030017440	S.CER ECJ0EC1H221J	B	3.3/38.1
C4	4030017390	S.CER ECJ0EC1H180J	B	3.3/39.4
C5	4030017640	S.CER ECJ0EC1H150J	B	9/39.7
C6	4030017460	S.CER ECJ0EB1E102K	T	19.1/30
C7	4030016790	S.CER ECJ0EB1C103K	T	4.2/29.4
C8	4030017350	S.CER ECJ0EC1H020B	T	3.9/34
C9	4030017350	S.CER ECJ0EC1H020B	T	4.2/35.2
C10	4030016950	S.CER ECJ0EB1A473K	T	13.4/34.1
C11	4550000270	S.TAN TEESVA 1E 474M8R	T	15.5/36.2
C12	4030017460	S.CER ECJ0EB1E102K	T	3.4/32.4
C15	4030017460	S.CER ECJ0EB1E102K	T	25.3/35.4
C16	4030017460	S.CER ECJ0EB1E102K	T	21.4/37.7
C17	4030017460	S.CER ECJ0EB1E102K	T	25.2/33.5
C20	4030017460	S.CER ECJ0EB1E102K	B	13.7/36.6
C21	4030017610	S.CER ECJ0EC1H090C	B	12.8/36.6
C22	4030017610	S.CER ECJ0EC1H090C	B	10.3/36.8
C24	4030016930	S.CER ECJ0EB1A104K	B	22.9/36.6
C25	4030017460	S.CER ECJ0EB1E102K	B	22.9/35
C26	4030007080	S.CER C1608 CH 1H 390J-T	B	21/33.3
C27	4030007080	S.CER C1608 CH 1H 390J-T	B	19.3/36
C28	4030017460	S.CER ECJ0EB1E102K	B	17.2/36
C29	4030017460	S.CER ECJ0EB1E102K	B	18.1/35.5
C30	4030017460	S.CER ECJ0EB1E102K	B	16/36.5
C31	4030017460	S.CER ECJ0EB1E102K	B	16.8/25.6
C32	4030017550	S.CER ECJ0EC1H1R5B	B	17.7/30.1
C33	4030017440	S.CER ECJ0EC1H221J	B	19.2/28.5
C34	4030017550	S.CER ECJ0EC1H1R5B	B	20.2/28.5
C35	4030017460	S.CER ECJ0EB1E102K	B	18.5/24.6
C36	4030017460	S.CER ECJ0EB1E102K	B	14.7/30.3
C37	4030017530	S.CER ECJ0EC1H0R5B	B	16.1/29.1
C38	4030017460	S.CER ECJ0EB1E102K	B	10.8/27.1
C39	4030017630	S.CER ECJ0EC1H120J	B	10.8/29.2
C40	4030017640	S.CER ECJ0EC1H150J	B	13.1/26.9
C41	4030017460	S.CER ECJ0EB1E102K	B	10.8/31.1
C42	4030017380	S.CER ECJ0EC1H050B	B	10.8/30.1
C43	4030017400	S.CER ECJ0EC1H220J	B	10.7/35.6
C44	4030017460	S.CER ECJ0EB1E102K	T	16.2/30.8
C50	4030017460	S.CER ECJ0EB1E102K	T	6.3/11.7
C51	4030017400	S.CER ECJ0EC1H220J	T	5.1/8.2
C52	4030017460	S.CER ECJ0EB1E102K	T	4.2/7
C53	4030017460	S.CER ECJ0EB1E102K	T	2.4/2.8
C54	4030017640	S.CER ECJ0EC1H150J	T	8.6/3
C55	4030017410	S.CER ECJ0EC1H240J	T	9.8/3.1
C56	4030016790	S.CER ECJ0EB1C103K	B	29.4/26.4
C57	4030016930	S.CER ECJ0EB1A104K	B	25.4/29.5
C58	4030016930	S.CER ECJ0EB1A104K	B	25.3/23
C59	4030017730	S.CER ECJ0EB1E471K	B	28.3/22.7
C60	4030017460	S.CER ECJ0EB1E102K	B	26.7/20.7
C61	4510008490	S.ELE EEE1CS100SR	T	18.6/16
C62	4030017460	S.CER ECJ0EB1E102K	T	16.7/13.7
C63	4030017730	S.CER ECJ0EB1E471K	T	13.9/13.6
C64	4030017460	S.CER ECJ0EB1E102K	T	12.2/3.3
C65	4030017430	S.CER ECJ0EC1H101J	T	12.4/5
C66	4030017460	S.CER ECJ0EB1E102K	T	14.3/2.5
C67	4030017730	S.CER ECJ0EB1E471K	T	18.8/12.1
C68	4030017420	S.CER ECJ0EC1H470J	T	22.2/13
C70	4030007100	S.CER C1608 CH 1H 560J-T	T	21.9/1.7
C71	4030009650	S.CER C1608 CH 1H 240J-T	T	25.9/3.7
C72	4030006860	S.CER C1608 JB 1H 102K-T	T	23.3/5.1
C73	4030017460	S.CER ECJ0EB1E102K	T	29.8/11.5
C74	4030017460	S.CER ECJ0EB1E102K	T	26.7/8.5
C75	4030017460	S.CER ECJ0EB1E102K	T	28.5/4.7
C80	4030017460	S.CER ECJ0EB1E102K	T	24.9/5
C81	4030017400	S.CER ECJ0EC1H220J	T	25.1/5.9
C82	4030017400	S.CER ECJ0EC1H220J	T	28.2/3.8
C83	4030017400	S.CER ECJ0EC1H220J	T	30.2/4.2
C84	4030018120	S.CER ECJ0EC1H110J	T	29.8/5.5
C85	4030017640	S.CER ECJ0EC1H150J	T	30.5/9.3
C86	4030017610	S.CER ECJ0EC1H090C	T	23.7/17.1
C87	4030017530	S.CER ECJ0EC1H0R5B	B	32.3/4.2
C88	4030017460	S.CER ECJ0EB1E102K	B	23.5/2.8
C89	4030017590	S.CER ECJ0EC1H070C	B	26.7/6.2
C90	4030007000	S.CER C1608 CH 1H 090D-T	B	27.6/9
C91	4030017620	S.CER ECJ0EC1H100C	B	31.1/10.5
C92	4030017360	S.CER ECJ0EC1H030B	B	26/9.2
C93	4030017460	S.CER ECJ0EB1E102K	B	29.5/15
C94	4030017370	S.CER ECJ0EC1H3R5B	B	23/21.4
C95	4030017650	S.CER ECJ0EC1H270J	B	26/10.8
C96	4030017460	S.CER ECJ0EB1E102K	B	27.2/10.2
C97	4030017360	S.CER ECJ0EC1H030B	B	28.1/16.6
C98	4030017550	S.CER ECJ0EC1H1R5B	B	27.4/11.4
C99	4030017500	S.CER ECJ0EC1H560J	B	23.8/18
C100	4030017560	S.CER ECJ0EC1H2R5B	B	19.6/18
C101	4030017610	S.CER ECJ0EC1H090C	B	
C102	4030016790	S.CER ECJ0EB1C103K	B	

[RF UNIT]

REF NO.	ORDER NO.	DESCRIPTION	M.	H/V LOCATION
C103	4030017420	S.CER ECJ0EC1H470J	B	19.6/18.9
C104	4030016790	S.CER ECJ0EB1C103K	B	19.7/20.1
C106	4030018900	S.CER ECJ0EB0J474K	B	22.6/17.3
C107	4030017460	S.CER ECJ0EB1E102K	B	19.6/14
C108	4030017420	S.CER ECJ0EC1H470J	B	18.7/17.4
C109	4030017460	S.CER ECJ0EB1E102K	B	16.9/16.8
C110	4030017680	S.CER ECJ0EC1H820J	B	15.9/19.1
C111	4030017460	S.CER ECJ0EB1E102K	B	14.9/21.5
C112	4030017370	S.CER ECJ0EC1H3R5B	B	16.2/14.3
C113	4030017540	S.CER ECJ0EC1HR75B	B	14.6/16
C114	4030017660	S.CER ECJ0EC1H330J	B	14.1/20.6
C115	4030017380	S.CER ECJ0EC1H050B	B	14/17.2
C116	4030017570	S.CER ECJ0EC1H040B	B	13/16
C119	4030017500	S.CER ECJ0EC1H560J	B	7.3/17.9
C120	4030016970	S.CER ECJ0EB1C223K	B	8.2/17.5
C121	4030017460	S.CER ECJ0EB1E102K	B	7.2/16.4
C122	4030017460	S.CER ECJ0EB1E102K	T	7.6/18.6
C123	4030017460	S.CER ECJ0EB1E102K	T	7.9/13.3
C130	4030017640	S.CER ECJ0EC1H150J	T	8.2/17.1
C131	4030017620	S.CER ECJ0EC1H100C	T	7.9/12.4
C132	4030017550	S.CER ECJ0EC1H1R5B	B	6.8/14.3
C154	4030017460	S.CER ECJ0EB1E102K	B	4.7/11.7
C155	4030017580	S.CER ECJ0EC1H060C	B	3.7/20.8
C156	4030017460	S.CER ECJ0EB1E102K	B	2.6/29.6
C157	4030016970	S.CER ECJ0EB1C223K	B	4.7/29.2
C158	4030017460	S.CER ECJ0EB1E102K	B	3.8/29.2
C159	4030016790	S.CER ECJ0EB1C103K	B	7.9/25.2
C160	4030016790	S.CER ECJ0EB1C103K	B	10.1/21.6
C191	4030016790	S.CER ECJ0EB1C103K	T	19.7/27.7
C192	4550006050	S.TAN TEESVA 0J 106M8R	T	21.6/32.5
C193	4030016790	S.CER ECJ0EB1C103K	T	21.6/29.1
C194	4030016790	S.CER ECJ0EB1C103K	T	20/30
C220	4550006250	S.TAN TEESVA 1A 106M8R	T	14.3/26.9
C221	4030016790	S.CER ECJ0EB1C103K	T	18.1/23.5
C223	4030016790	S.CER ECJ0EB1C103K	T	26.1/17.3
C225	4030007020	S.CER C1608 CH 1H 120J-T	T	21.9/4.4
C226	4030017610	S.CER ECJ0EC1H090C	B	27.6/5.3
C380	4030017460	S.CER ECJ0EB1E102K	B	27.7/20.4
C381	4030017460	S.CER ECJ0EB1E102K	B	25.9/30.4
C510	4030017460	S.CER ECJ0EB1E102K	B	1.5/3
C512	4030017460	S.CER ECJ0EB1E102K	B	2.7/1.2
J101	6510025120	S.CNR 30RF-JMCS-G-1B-TF (N)	T	11.9/20
S250	2260002800	S.SW SW-167 (SKQTLAE010)	T	20.1/39.8
S328	2260002800	S.SW SW-167 (SKQTLAE010)	T	5.1/39.8
EP2	6910014690	S.BEA MPZ1608S221A-T	T	15.5/14.9
EP3	6910014690	S.BEA MPZ1608S221A-T	T	18.4/13.3

[VR BOARD]

REF NO.	ORDER NO.	DESCRIPTION	M.	H/V LOCATION
R801	7210003130	VAR TP76N97N-13F-10KA-2497		

[MIC BOARD]

REF NO.	ORDER NO.	DESCRIPTION	M.	H/V LOCATION
C700	4030017420	S.CER ECJ0EC1H470J	B	3.4/2.3
C702	4030017420	S.CER ECJ0EC1H470J	B	12.5/7.1
C703	4030017620	S.CER ECJ0EC1H100C	B	6.6/7.7
J415	6510025140	S.CNR 10FLT-SM1-TB	B	10.7/2.5
J416	6510021940	CNR 246S-550-4P		
J416	6510021941	CNR 246S-550-4P-68 (JIS8)		
W470	8900014800	CBL OPC-1573 (P0.5,N10,L50)		
EP451	6910012350	S.BEA MMZ1608Y 102BT	B	3.4/4.8
EP452	6910012350	S.BEA MMZ1608Y 102BT	B	5.5/9
EP454	6910012350	S.BEA MMZ1608Y 102BT	B	6.3/2.8
EP458	6910012350	S.BEA MMZ1608Y 102BT	B	11.4/6.9

M.=Mounted side (T: Mounted on the Top side, B: Mounted on the Bottom side)
S.=Surface mount

• BC-166
[MAIN UNIT]

REF NO.	ORDER NO.	DESCRIPTION	M.	H/V LOCATION
IC1	1190002270	S.IC NJW4100V-TE1	B	47.3/19.4
Q1	1540000471	S.TR 2SD1801S-TL-E	B	52/48.3
Q2	1520000651	S.TR 2SB1201S-TL-E	B	40.5/47.6
D1	1790000671	S.DIO SB07-03C-TB-E	B	54.2/59.1
D2	1730002660	S.ZEN MA8110L (TX)	B	55.5/42.3
D3	1790000671	S.DIO SB07-03C-TB-E	B	29.8/61
D5	1790001280	S.DIO MA111 (TX)	B	48.4/9
R1	7030003400	S.RES ERJ3GEYJ 471 V (470)	B	52.1/42.3
R2	7030000020	S.RES MCR10EZHZ 010 V (1)	B	32.9/63
R3	7030000440	S.RES MCR10EZHZ 332 V (3.3 k)	B	41.3/8.6
R4	7030000460	S.RES MCR10EZHZ 442 V (4.7 k)	B	46.3/9
R6	7030003940	S.RES ERJ3GEYF 104 V (100 k)	B	54.1/19.4
R7	7030010310	S.RES ERJ3GEYF 223 V (22 k)	B	52/20.1
R8	7030003940	S.RES ERJ3GEYF 104 V (100 k)	B	54/23.6
R9	7030005250	S.RES ERJ3GEYF 103 V (10 k)	B	52/22.9
R10	7030005871	S.RES ERA3YKD 104V (100 k)	B	41.3/23.7
R11	7030004820	S.RES ERJ3GEYF 473 V (47 k)	B	39/22.7
R12	7030003560	S.RES ERJ3GEYJ 103 V (10 k)	B	41.7/18.3
R13	7030003560	S.RES ERJ3GEYJ 103 V (10 k)	B	45/14.4
R16	7030005321	S.RES ERA3YED 103V (10 k)	B	42.4/21.3
R17	7030011190	S.RES ERA3YEB 103V (10 k)	B	39.3/16.2
R20	7030011140	S.RES ERJ8GEYJ JPW	B	55.5/21.9
R21	7030011140	S.RES ERJ8GEYJ JPW	B	55.5/15.9
R22	7030011140	S.RES ERJ8GEYJ JPW	B	48.7/14.7
R23	7030011140	S.RES ERJ8GEYJ JPW	B	48.7/12.6
R24	7030011140	S.RES ERJ8GEYJ JPW	B	37.2/13.3
R25	7030003860	S.RES ERJ3GE JPW V	B	39/19.2
R27	7030000420	S.RES MCR10EZHZ 222 (2.2 k)	B	47.8/23.9
R28	7030000020	S.RES MCR10EZHZ 010 V (1)	B	34.8/63
R30	7030000010	S.RES MCR10EZHZ JPW	B	40.6/20.9
R31	7030003520	S.RES ERJ3GEYJ 472 V (4.7 k)	B	46.4/46.6
C1	4030006900	S.CER C1608 JB 1H 103K-T	B	51.2/68.2
C2	4510009150	S.ELE EEE1EA470WP	B	55.5/37.8
C3	4030006900	S.CER C1608 JB 1H 103K-T	B	32.9/66.7
C5	4510008540	S.ELE EEE1CA100SR	B	29.7/66.9
C6	4030011600	S.CER C1608 JB 1E 104K-T	B	44.7/12.2
C7	4030006900	S.CER C1608 JB 1H 103K-T	B	52.7/18
C8	4030008920	S.CER C1608 JB 1H 473K-T	B	52/15.9
C9	4030006860	S.CER C1608 JB 1H 102K-T	B	45.4/24.6
J1	6510024940	CNR HEC2305-016250		
DS1	5040002740	LED RT3-03HRYG		
S1	2230000960	SW SPPW81-7.6-B2		

M.=Mounted side (T: Mounted on the Top side, B: Mounted on the Bottom side)
S.=Surface mount

SECTION 7 MECHANICAL PARTS AND DISASSEMBLY

[CHASSIS PARTS]

REF. NO.	ORDER NO.	DESCRIPTION	QTY.
J1	6910017840	2905 ANT connector	1
J3	6510025340	2905 contact spring <Al>	1
W3	8900010960	OPC-1129	1
MP1	8210022710	2905 front panel (Including MP3, MP4, SP1)	1
MP2	8310065830	2905 window plate	1
MP3	8930068860	2905 keyboard	1
MP4	8930011900	SP Net (A) (FX-573)	1
MP5	8930068980	2905 vent sheet	2
MP6	8930069940	2905 A-MAIN seal	1
MP7	8010020320	2905 rear panel	1
MP8	8310065560	2905 T-plate	1
MP9	8930068500	2905 T-rubber	1
MP10	8930069910	2905 T-sheet	1
MP11	8810010450	Screw M2 × 3 SUS SSBC	2
MP12	8930068470	2905 PTT button	1
MP13	8210022480	2905 PTT panel	1
MP14	8810010630	Screw M2 × 3 SUS SSBC	1
MP15	8310065550	2905 lock plate	1
MP16	8930068970	2905 window sheet	1
MP17	8930069350	2905 MIC seal	1
MP18	8930051390	2304 shaft	1
MP19	8610012900	Knob N-344	1
MP20	8930057690	O Ring (AQ)	1
MP21	8830002770	VR nut (W)	1
MP22	8930053590	O Ring (AG)	1
MP23	8830001160	VR nut (K)	1
MP24	8850002770	Plain washer (AM)	1
MP26	8830002780	VR nut (X)	1
MP27	8930050660	2320 connector cap	1
MP28	8810009180	Screw B0 2 × 5 NI-ZU (BT)	2
MP29	8810010480	Screw B0 2 × 6 SUS SSBC	4
MP30	8810008970	Screw B0 2 × 3.5 NI-ZU (BT)	9
MP32	8810009161	Screw B0 2 × 20 SUS SSBC	2
MP36	8610009240	Knob spring NO.7800P	1
MP37	8930055920	Insulated plate (GQ)	1
MP39	8930069620	2905 ant plate	1
MP40	8810006571	Screw M2 × 2M ZC3	1
MP42	8930065120	Sponge (IE)	1
SP1	2510001330	Speaker 036D0803 <FG>	1

[MAIN UNIT]

REF. NO.	ORDER NO.	DESCRIPTION	QTY.
MC250	7700002690	AM-627P-462C33	1
EP360	8930069010	SRCN-2905-SP-N-W	2
MP360	8210022490	2905 Reflector	1
MP361	8930068431	2905 LCD holder	1
MP362	8950004430	Double coated tape (O)	2

[RF UNIT]

REF. NO.	ORDER NO.	DESCRIPTION	QTY.
S250	2260002800	SW-167 (SKQT)	1
S328	2260002800	SW-167 (SKQT)	1
EP2	6910014690	MPZ1608S221A	1
EP3	6910014690	MPZ1608S221A	1
MP20	8510016470	2775 VCO case	1
MP21	8510017520	2905 VCO cover	1
MP50	8410002620	2905 PA heatsink	1
MP51	8510017590	2905 Shield plate	1
MP52	8860001400	2905 Earth plate	1
MP53	8930069820	Insulation sheet (LN)	1

[MIC BOARD]

REF. NO.	ORDER NO.	DESCRIPTION	QTY.
W470	8900014800	OPC-1573	1
J416	6510021941	246S-550-4P-68	
EP451	6910012350	MMZ1608Y102BT	1
EP452	6910012350	MMZ1608Y102BT	1
EP454	6910012350	MMZ1608Y102BT	1
EP458	6910012350	MMZ1608Y102BT	1

[VR BOARD]

REF. NO.	ORDER NO.	DESCRIPTION	QTY.
R801	7210003130	TP76N97N-13F-10KA-2497	1

Screw abbreviations

B0, BT: Self-tapping PH: Pan head
 NI-ZU: Nickel-Zinc ZK: Black

[ACCESSORIES]

REF. NO.	ORDER NO.	DESCRIPTION	QTY.
EP1	Optional product	Flexible antenna FA-S64V	1
EP2	Optional product	AC adapter BC147E except [UK], [UK-1]	1
EP3	Optional product	Li-Ion battery pack BP-245	1
EP4	Optional product	Battery charger BC-166 (Including two screws)	1
MP1	8010018080	Handstrap HK-009	1
MP2	Optional product	Belt clip MB-103 (Including two screws)	1

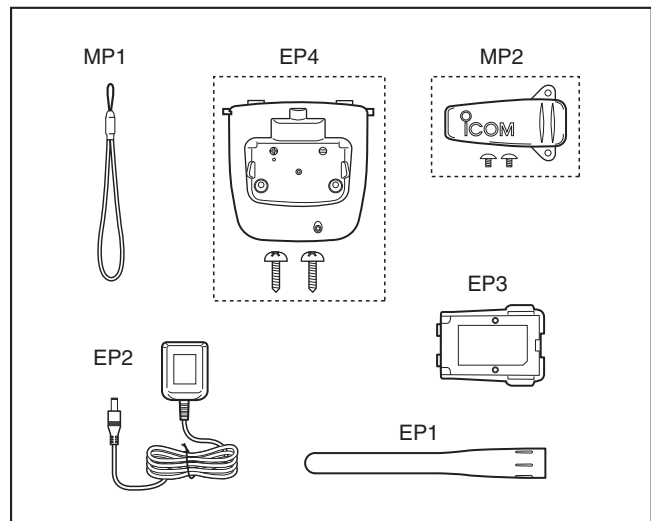

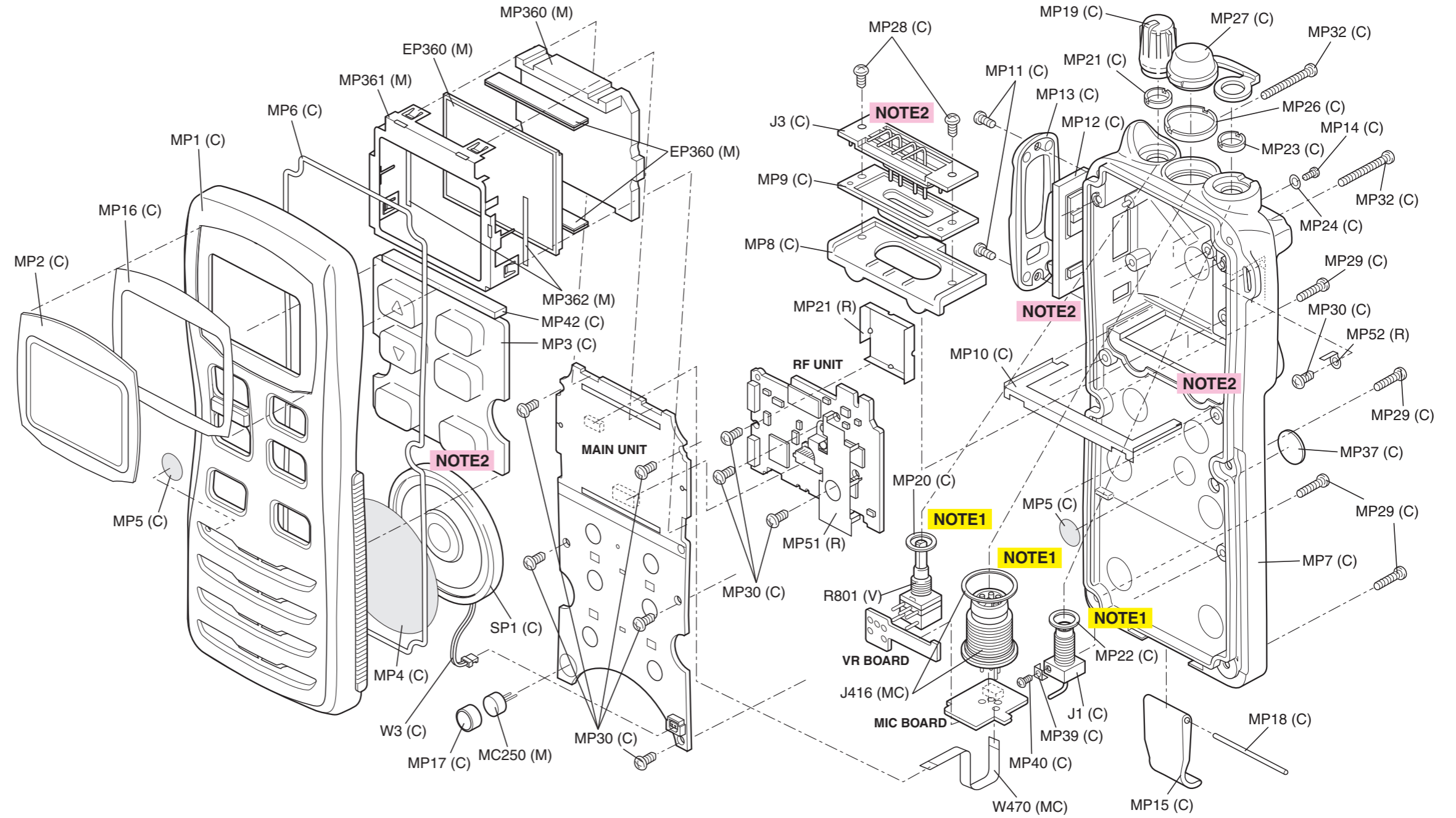
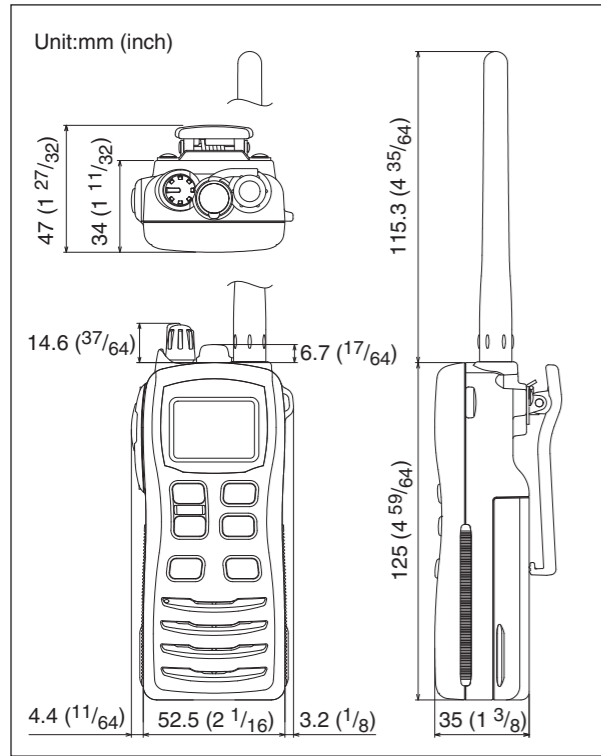

UNIT abbreviations
 (C): CHASSIS PARTS
 (M): MAIN UNIT
 (R): RF UNIT
 (V): VR UNIT
 (MC): MIC UNIT

NOTE1 : Once the following parts are removed, an O ring or sealing washer must be replaced with new one before reattachment.

REF. NO.	Mother parts	Daughter parts for relayed replacement
MP20 (C)	TP76N97N-13F-10KA-2497 (R801)	O ring (AQ)
MP22 (C)	2905 ant connector (J1)	O ring (AG)
J416 (MC)	246S-550-4P-68 (JIS8)	6510021940 O ring

NOTE2 The glue must be applied to the  areas when these components are replaced with new one, to ensure water tightness
 Manufacture : Cemedine Co.
 Type : Super-X

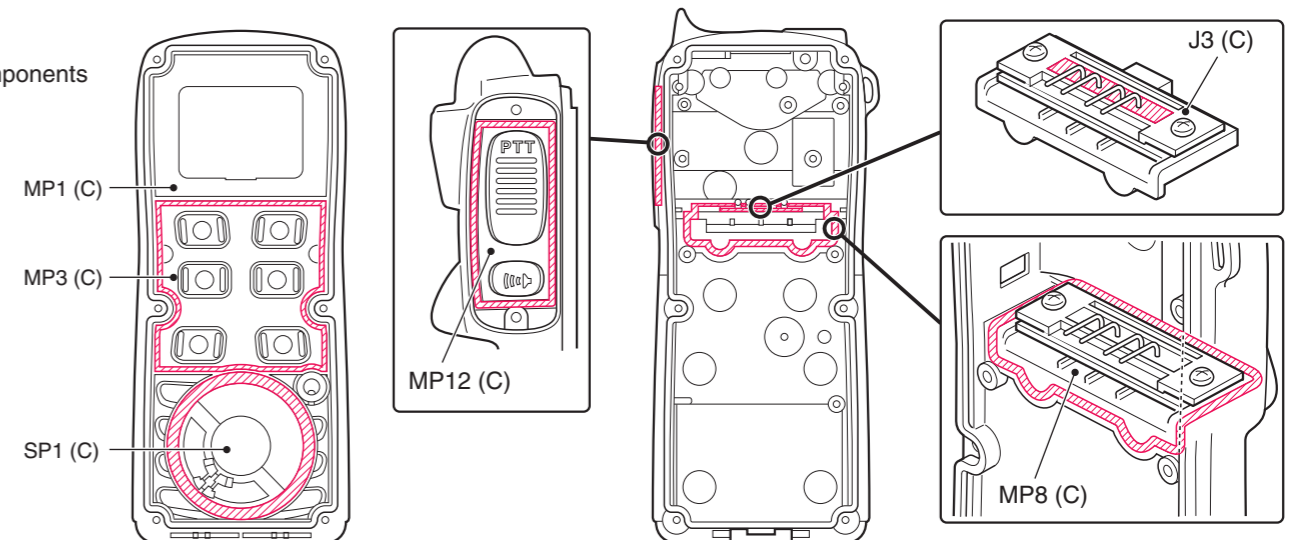

SECTION 8 SEMICONDUCTOR INFORMATION

• TRANSISTORS AND FET'S

NAME	SYMBOL	INSIDE VIEW
2SB1201S-TL	B1201	
2SC4215-O 2SC4215-Y 2SC4226-T1 2SC5110-O	QO QY R25 MGO	
2SD1801S-TL	CE	
2SK1829	K1	
2SK880-Y	XY	
3SK293	UF	
3SK294	UV	
KTA1664Y-RTF/P	R	

NAME	SYMBOL	INSIDE VIEW
KTA2015Y-RTK/P	Z	
RD01MUS1	K2	
RD07MVS1	RD07MVS1	
RSQ035P03TR	TM	
UNR9111J UNR9113J-(TX)	6A 6C	
UNR9210J-(TX) UNR9213J-(TX)	8L 8C	
XP1213	9L	
XP4313-(TX)	BZ	
XP6501-(TX)	5N	

• DIODES

NAME	SYMBOL	INSIDE VIEW
1SV307	TX	
1SV308 MA111-(TX) MA2S077-(TX) MA2S111 MA8110L	TX 1B S A 11_	
HVC350BTRF-E	B0	
HVC376BTRF-E	B9	
KDS122 RB706F-40T106	C3 3J	
SB07-03C-TB-E	J	

SECTION 9 BOARD LAYOUTS

The combination of this page and the next page shows the unit layout in the same configuration as the actual P.C. Board.

MAIN UNIT (TOP VIEW)

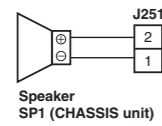
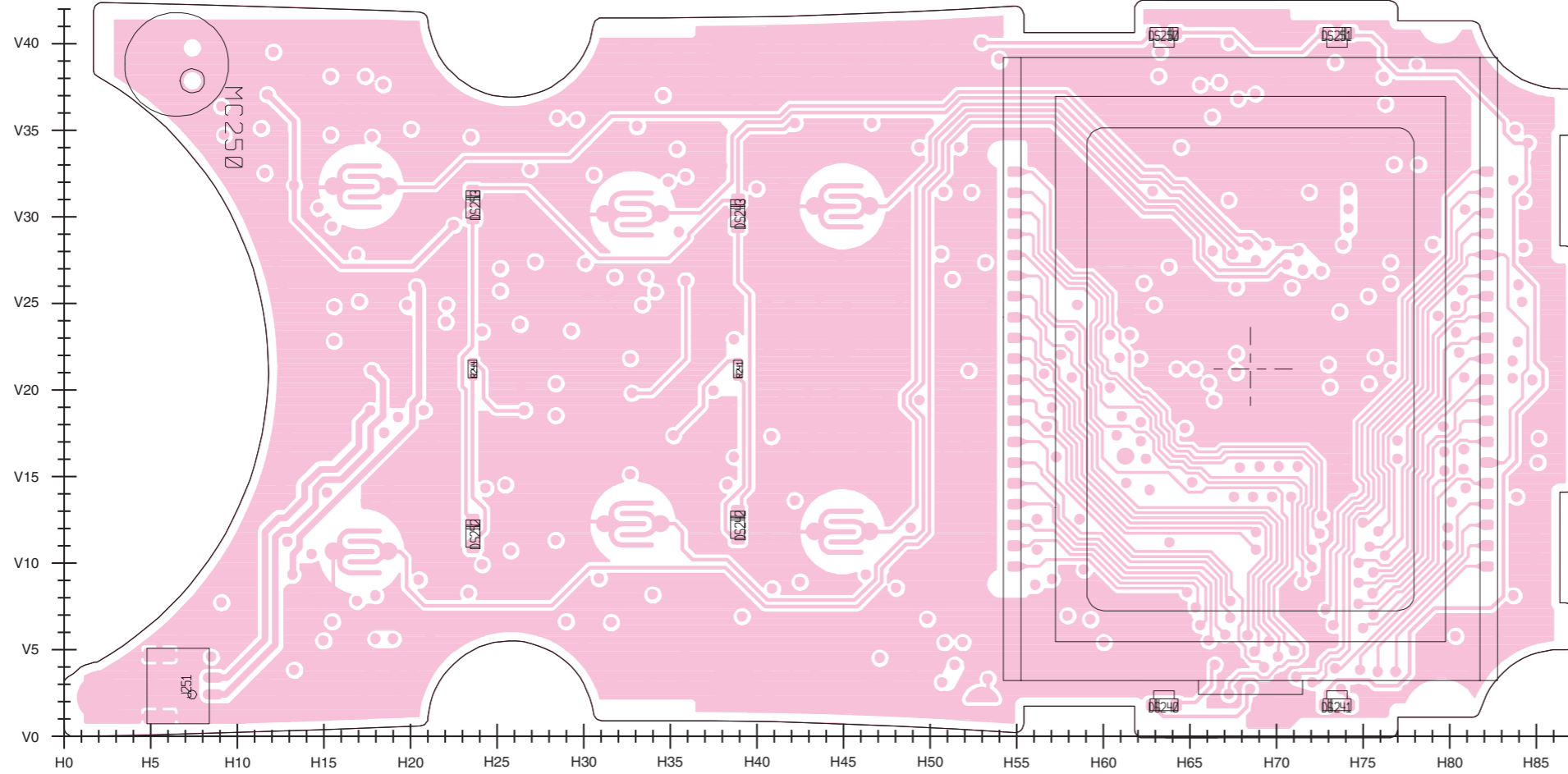

BC-166 (TOP VIEW)

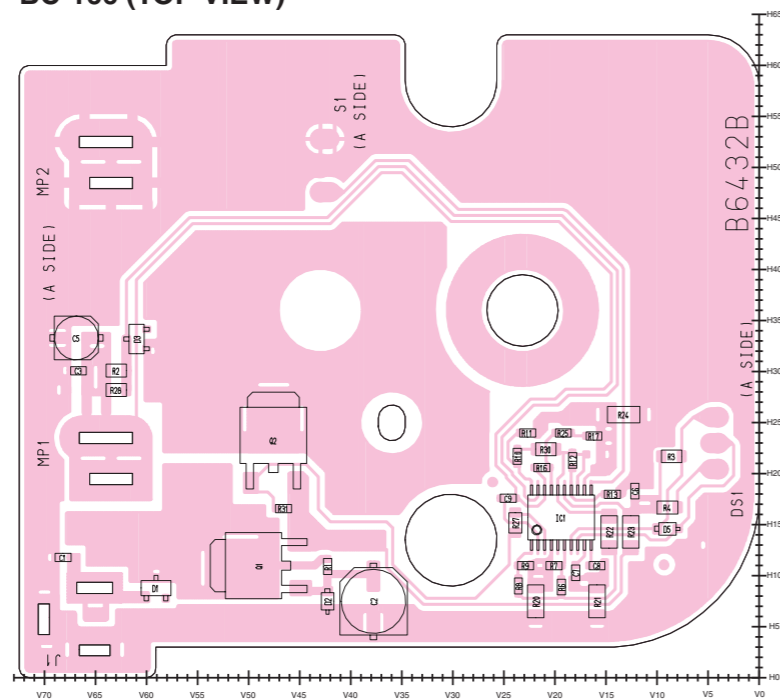

J101		to MAIN UNIT "J100"	
30	MOD	GND	1
	TEMPV	GND	2
	PLST	GND	
	UNLK	R5V	
	SDATA	V5VS	
	SOL	LOINV	
	SCK	DAST	
	PTT	RSSIV	
	2NDLO	TXMS	
	PWON	SOLO	
	5V	SQI	
	GND	TDTEV	
	GND	TSVS	
	GND	VCC	
	GND	VCC	
	GND	VCC	
	GND	VCC	

MIC BOARD (TOP VIEW)

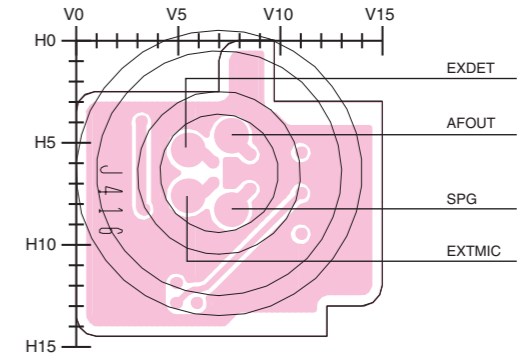

VR BOARD (TOP VIEW)

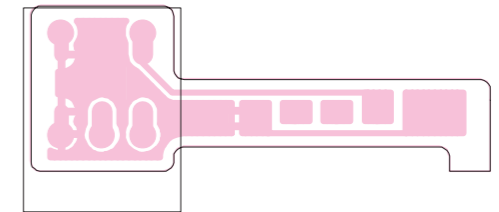

RF UNIT (TOP VIEW)

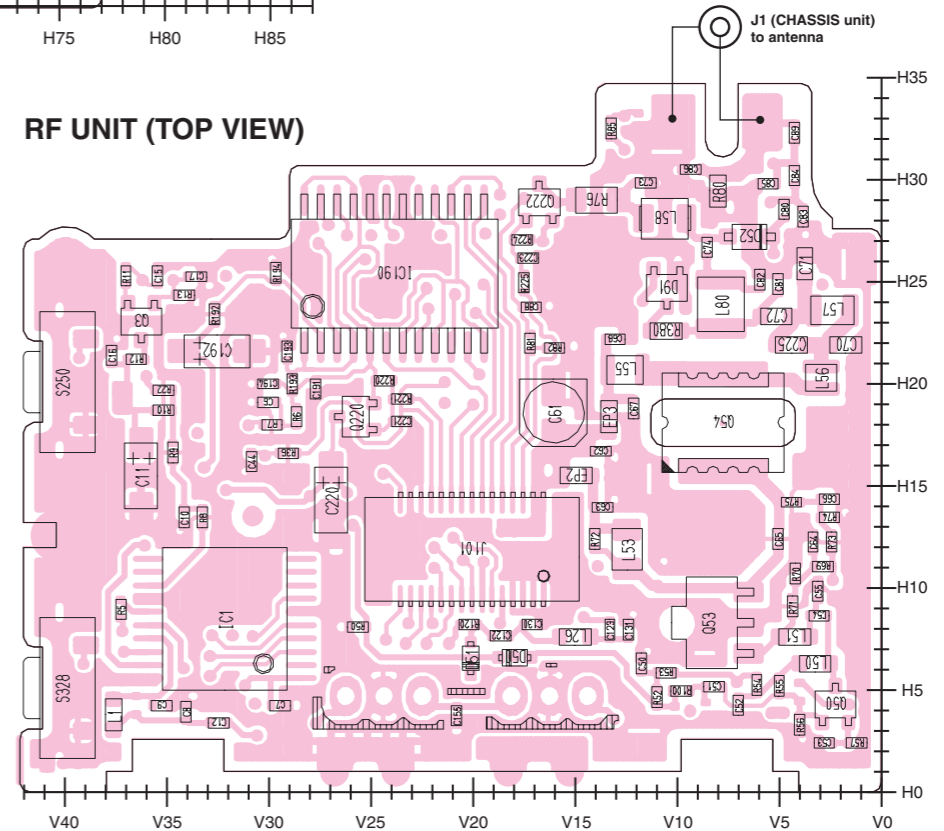

SECTION 10 BLOCK DIAGRAM

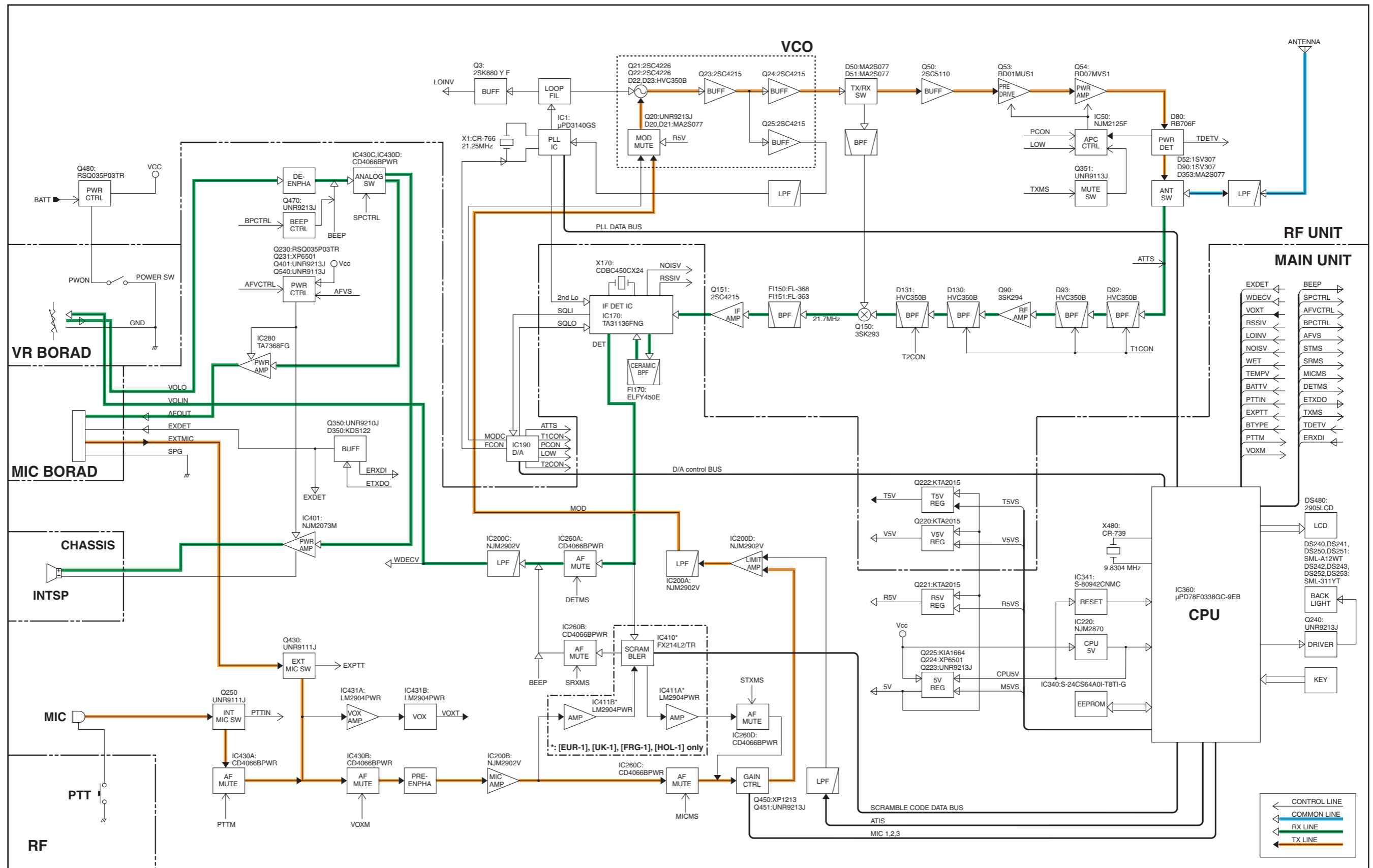

SECTION 11 VOLTAGE DIAGRAM

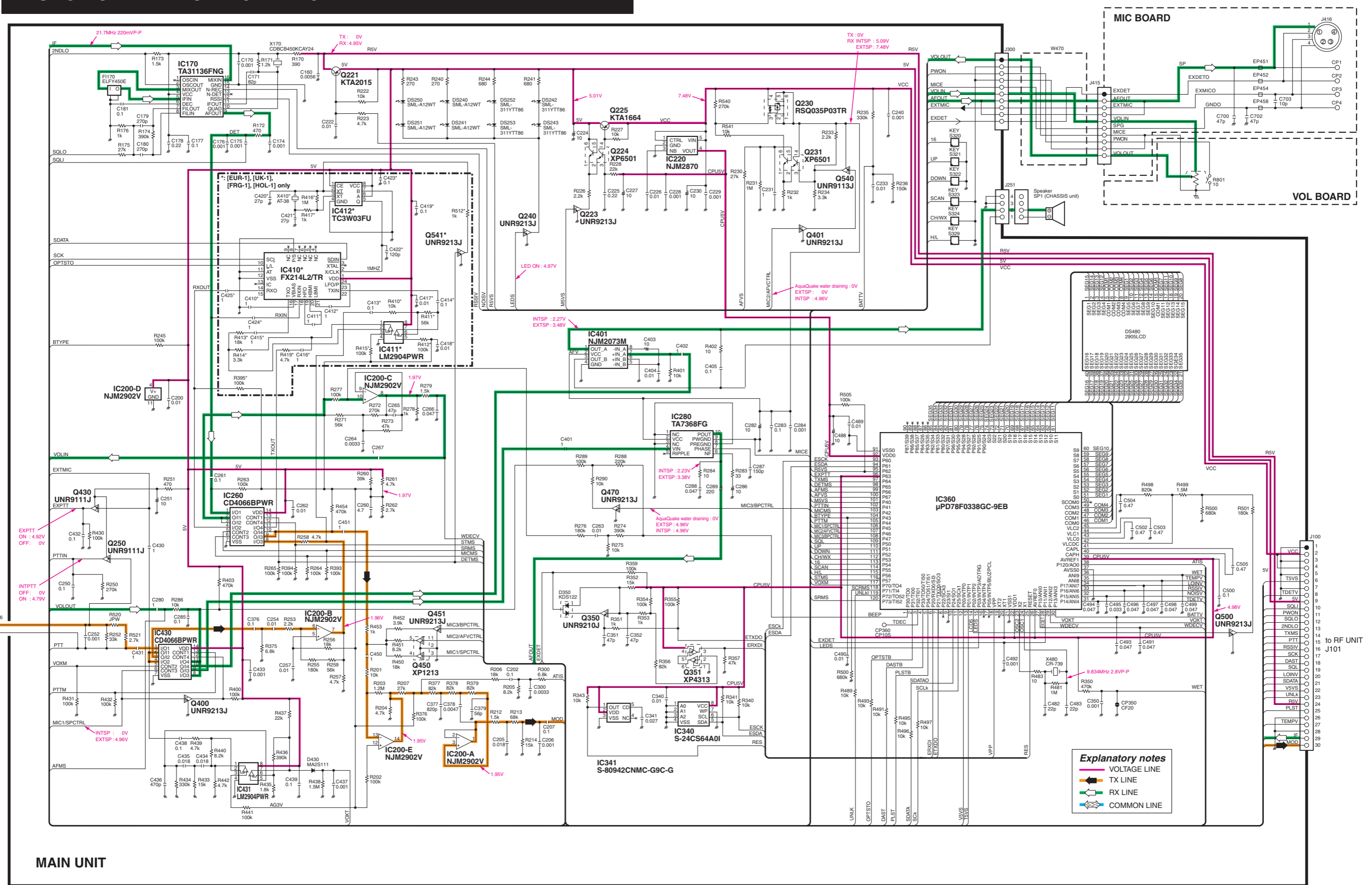

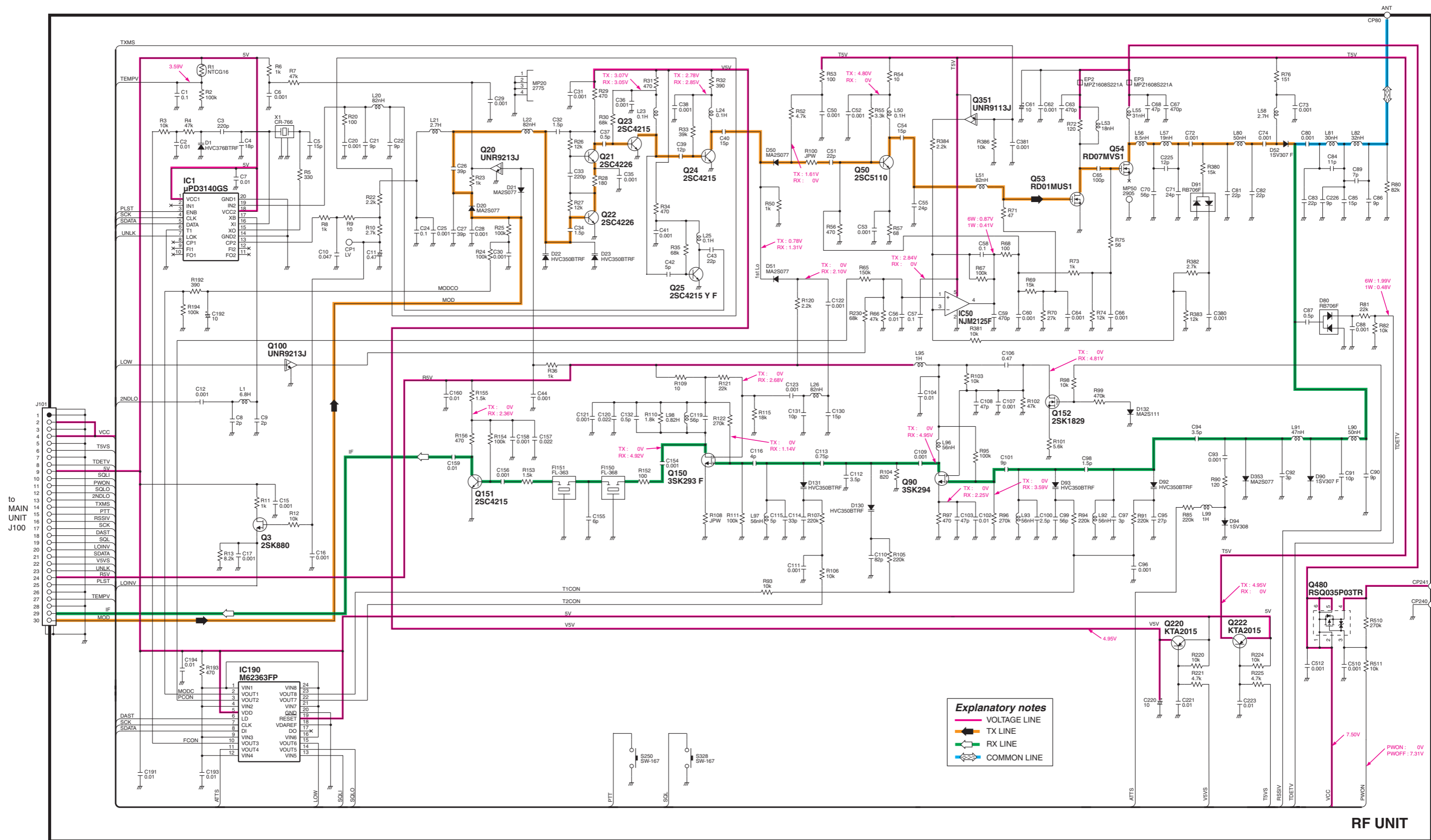

Explanatory notes

- VOLTAGE LINE
- TX LINE
- RX LINE
- COMMON LINE

SECTION 12 BC-166 INFORMATION

• BC-166 CHARGER PARTS LIST

MECHANICAL PARTS CHASSIS PARTS

REF. NO.	ORDER NO.	DESCRIPTION	QTY.
MP1	8010020360	2907 case	1
MP2	8110008760	2907 cover	1
MP3	8930068690	2907 lock plate <FG>	1
MP4	8810010500	Screw B0 3 × 10 NI-ZU (BT)	1
MP5	8810010500	Screw B0 3 × 10 NI-ZU (BT)	1
MP6	8930039620	LEG cushion (A)	2
MP7	8930068700	2907 lock spring	1
MP8	8930054050	2373 shaft	1

MAIN UNIT

REF. NO.	ORDER NO.	DESCRIPTION	QTY.
MP1	8930069890	2907 Terminal	1
MP2	8930069890	2907 Terminal	1

ACCESSORIES

REF. NO.	ORDER NO.	DESCRIPTION	QTY.
MP1	Optional product	Screw M5 × 30 SUS	2

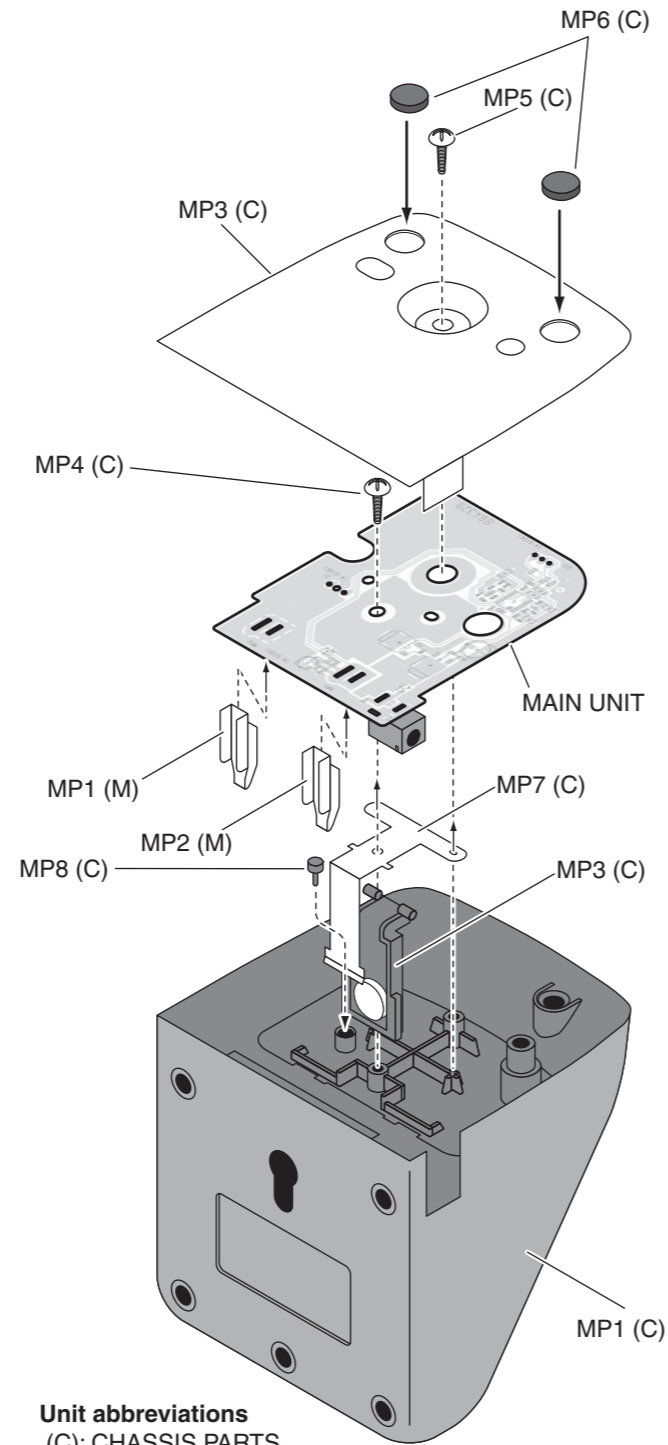
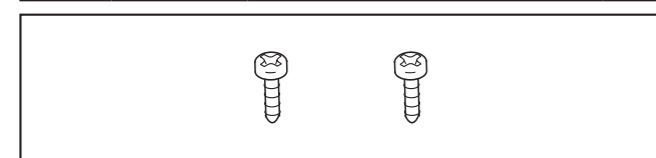

Unit abbreviations
 (C): CHASSIS PARTS
 (M): MAIN UNIT

• BC-166 VOLTAGE DIAGRAM

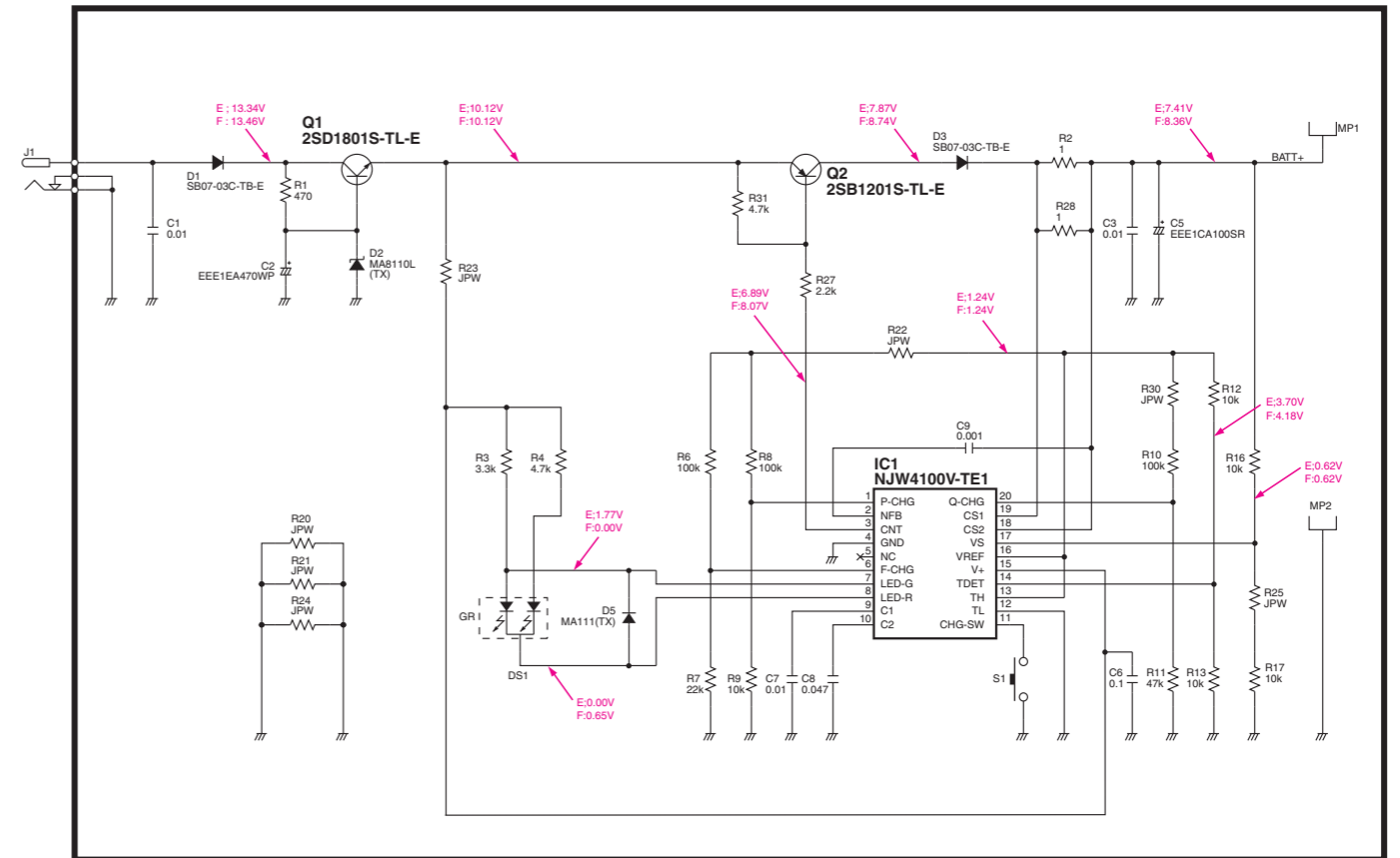

Icom Inc.

1-1-32, Kamiminami, Hirano-ku, Osaka 547-0003, Japan
Phone : +81 (06) 6793 5302
Fax : +81 (06) 6793 0013
URL : <http://www.icom.co.jp/world/index.html>

Icom America Inc.

<Corporate Headquarters>
2380 116th Avenue N.E., Bellevue, WA 98004, U.S.A.
Phone : +1 (425) 454-8155 Fax : +1 (425) 454-1509
URL : <http://www.icomamerica.com>
E-mail : sales@icomamerica.com
<Customer Service>
Phone : +1 (425) 454-7619

Icom Canada

Glenwood Centre #150-6165
Highway 17 Delta, B.C., V4K 5B8, Canada
Phone : +1 (604) 952-4266 Fax : +1 (604) 952-0090
URL : <http://www.icomcanada.com>
E-mail : info@icomcanada.com

Icom (Australia) Pty. Ltd.

Unit 1 / 103 Garden Road, Clayton VIC 3168 Australia
Phone : +61 (03) 9549-7500 Fax : +61 (03) 9549-7505
URL : <http://www.icom.net.au>
E-mail : sales@icom.net.au

Icom New Zealand

146A Harris Road, East Tamaki,
Auckland, New Zealand
Phone : +64 (09) 274 4062 Fax : +64 (09) 274 4708
URL : <http://www.icom.co.nz>
E-mail : inquiries@icom.co.nz

Beijing Icom Ltd.

10C07, Long silver Mansion, No.88, Yong Ding
Road, Haidian District, Beijing, 100039, China
Phone : +86 (010) 5889 5391/5392/5393
Fax : +86 (010) 5889 5395
E-mail : bjicom@bjicom.com
URL : <http://www.bjicom.com>

Icom (Europe) GmbH

Communication Equipment
Auf der Krautweide 24
65812 Bad Soden am Taunus, Germany
Phone : +49 (6196) 76685-0 Fax : +49 (6196) 76685-50
URL : <http://www.icomeurope.com>
E-mail : info@icomeurope.com

Icom Spain S.L

Ctra. Rubi, No. 88 Bajos A 08174, Sant Cugat del Valles, Barcelona, Spain
Phone : +34 (93) 590 26 70 Fax : +34 (93) 589 04 46
URL : <http://www.icomspain.com>
E-mail : icom@icomspain.com

Icom (UK) Ltd.

Unit 9, Sea St., Herne Bay, Kent, CT6 8LD, U.K.
Phone : +44 (01227) 741741 Fax : +44 (01227) 741742
URL : <http://www.icomuk.co.uk>
E-mail : info@icomuk.co.uk

Icom France s.a.s.

Zac de la Plaine
1 Rue Brindejonc des Moulinais BP 5804
31505 Toulouse Cedex, France
Phone : +33 (5) 61 36 03 03 Fax : +33 (5) 61 36 03 00
URL : <http://www.icom-france.com>
E-mail : icom@icom-france.com

Asia Icom Inc.

6F No.68, Sec. 1 Cheng-Teh Road, Taipei, Taiwan, R.O.C.
Phone : +886 (02) 2559 1899 Fax : +886 (02) 2559 1874
URL : <http://www.asia-icom.com>
E-mail : sales@asia-icom.com

Icom Polska

81-850 Sopot, ul. 3 Maja 54, Poland
Phone : +48 (58) 550 7135 Fax : +48 (58) 551 0484
E-mail : icompolska@icompolska.com.pl

Count on us!

Icom Inc.

1-1-32, Kamiminami, Hirano-ku, Osaka 547-0003, Japan

S-14224MZ-C1
© 2006 Icom Inc.